



ESPE

UNIVERSIDAD DE LAS FUERZAS ARMADAS
INNOVACIÓN PARA LA EXCELENCIA

UNIDAD DE GESTIÓN DE  TECNOLOGÍAS

POTENCIACIÓN DEL SIMULADOR
BOEING 737-800 A TRAVÉS DE
LA ADESIÓN DE LOS
SISTEMAS AFOR (AUTOMATIC
FLIGHT ON ROUTE) Y (AUTOMATIC
FLIGHT DIRECTOR SYSTEM
ADFS)

SISTEMA DE NAVEGACIÓN

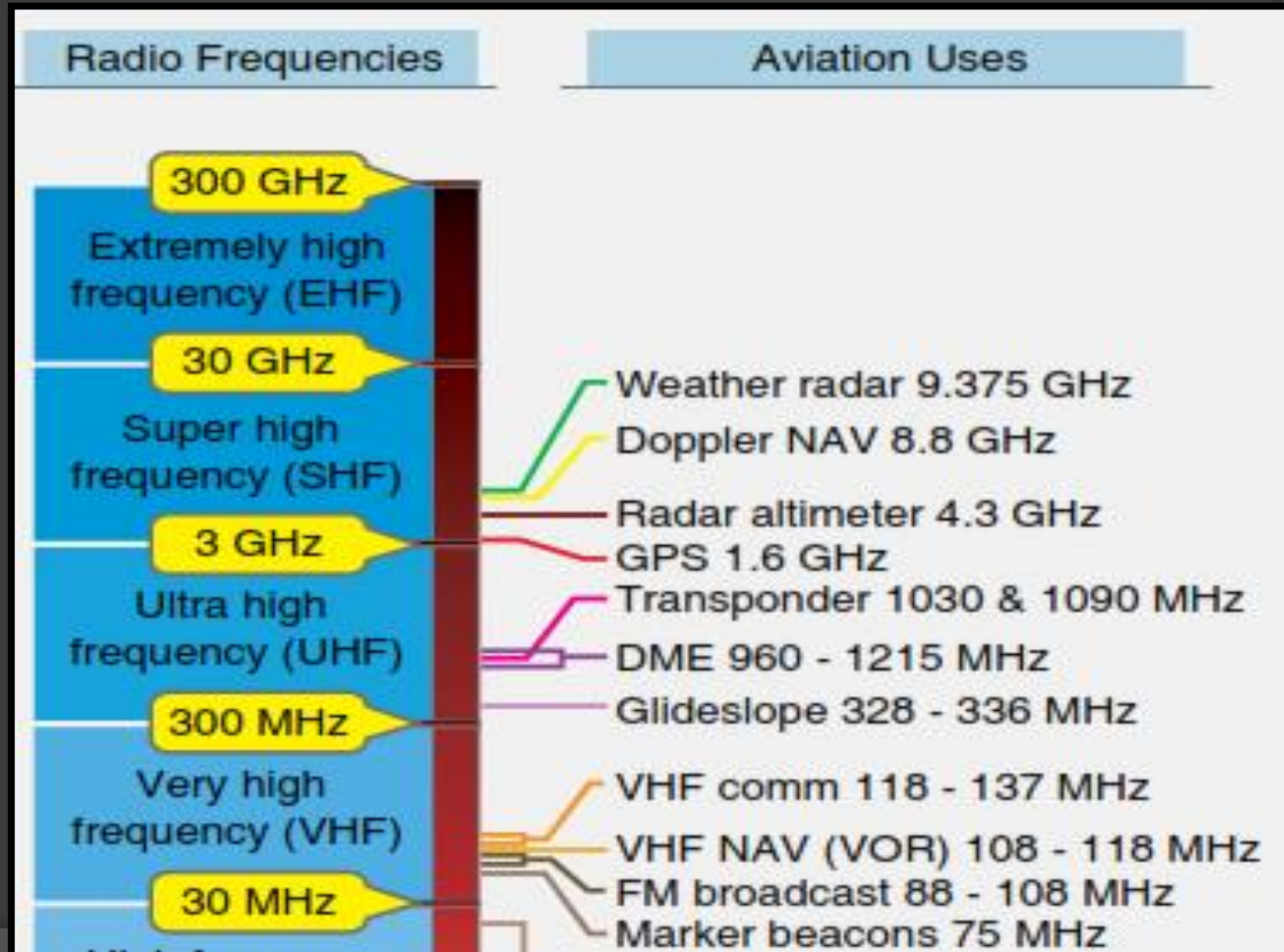

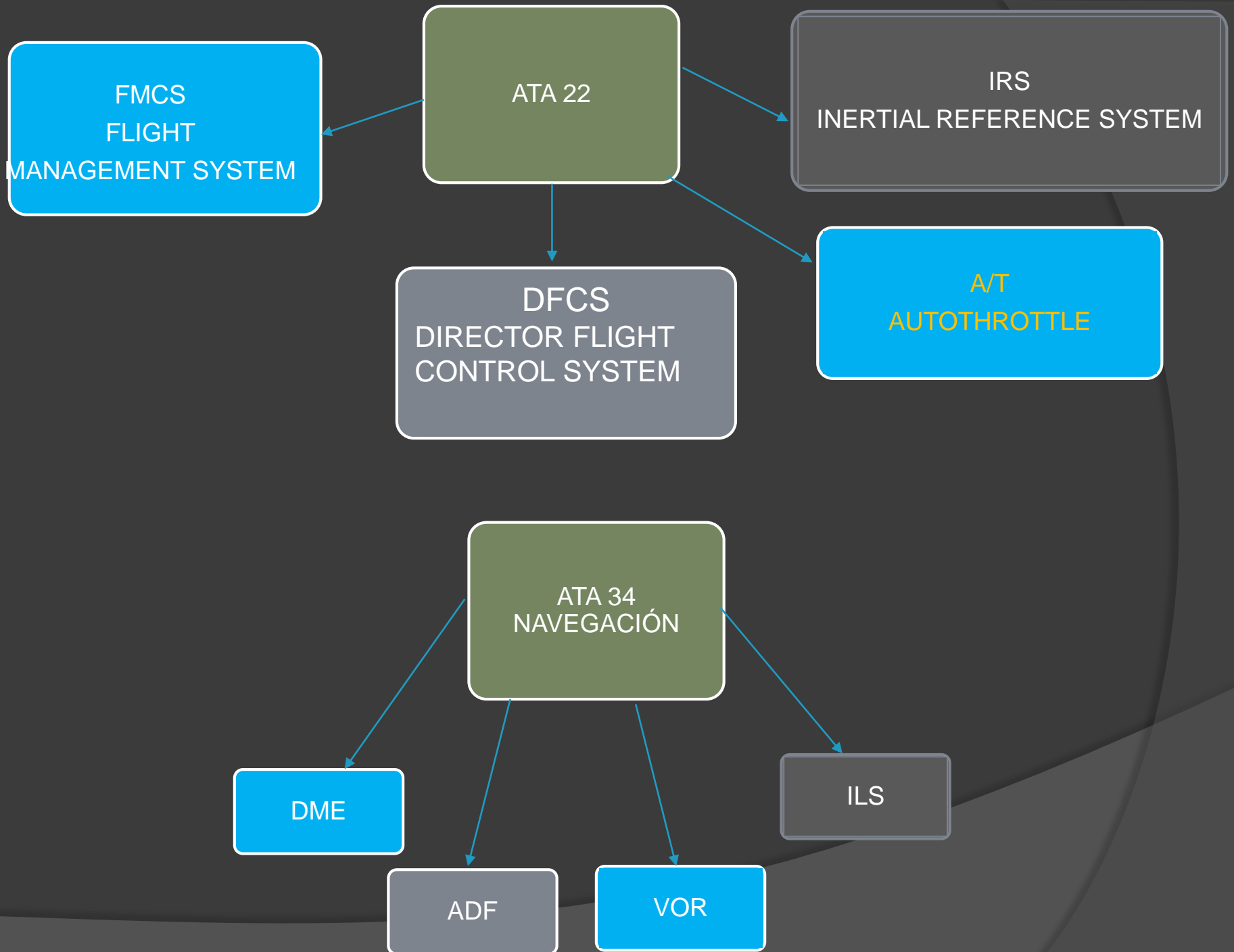

FMCS
FLIGHT
MANAGEMENT SYSTEM

ATA 22

IRS
INERTIAL REFERENCE SYSTEM

DFCS
DIRECTOR FLIGHT
CONTROL SYSTEM

AT
AUTOTHROTTLLE

ATA 34
NAVEGACIÓN

DME

ADF

VOR

ILS

PILOTO AUTOMÁTICO SP-77



PILOTO AUTOMÁTICO SP-177



PILOTO AUTOMÁTICO

- ❖ Mantiene la altitud programada
- ❖ Ascenso o descenso en una nueva altitud
- ❖ Velocidad programada
- ❖ Acelerar o reducir a una velocidad programada
- ❖ Seguir un rumbo programado
- ❖ Alinear el avión para aproximaciones a tierra

AUTO FLIGHT - DESCRIPTION AND OPERATION

The automatic flight control systems (AFCS) consist of three independent systems:

- Digital flight control system (DFCS)
- Yaw damper system
- Autothrottle system.

These systems provide automatic selective guidance from radio, heading, flight management computer, and air data computer inputs.

MCP (MODE CONTROL PANEL)

- ⦿ DFCS comprendido de dos computadoras de vuelo la (FCC), la (MCP) y cuatro A/P ACTUADORES
- ⦿ Permite controlar:
 - F/D EADI
 - A/P
 - A/T

AFCS MODE CONTROL PANEL

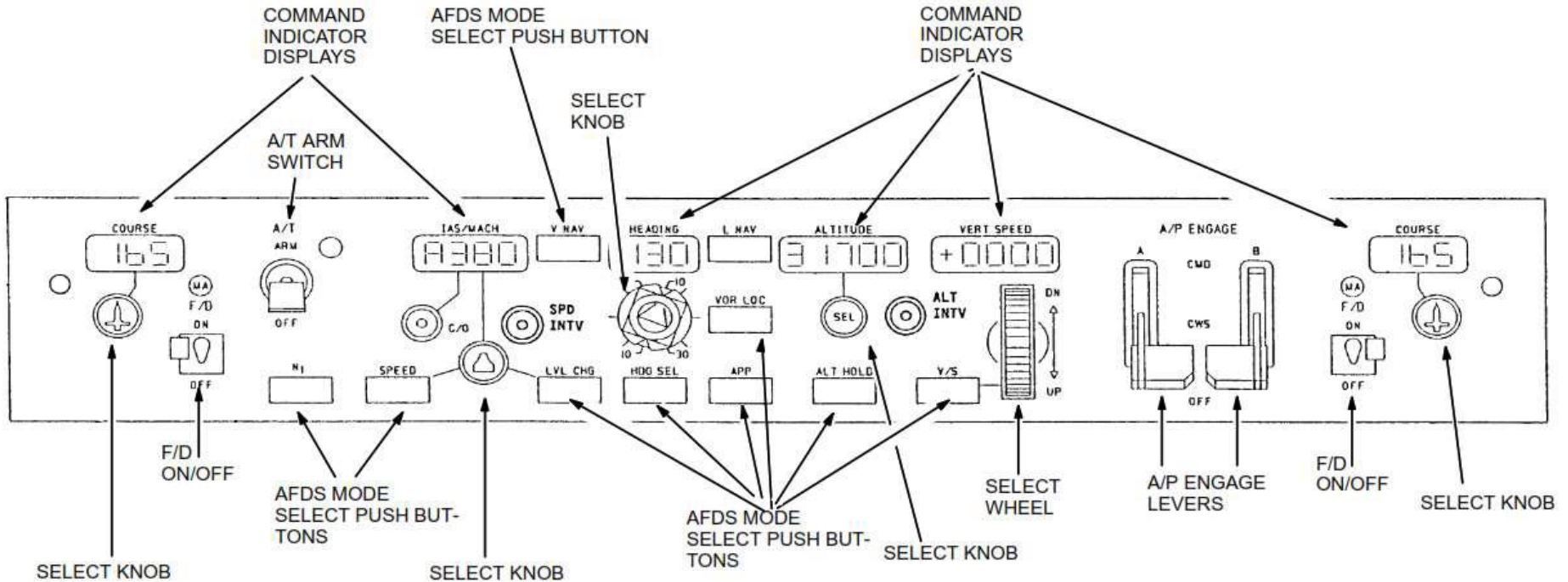

MODE CONTROL PANEL WITH ENGAGE-LEVERS

MODE CONTROL PANEL WITH ENGAGE-PUSHBUTTONS

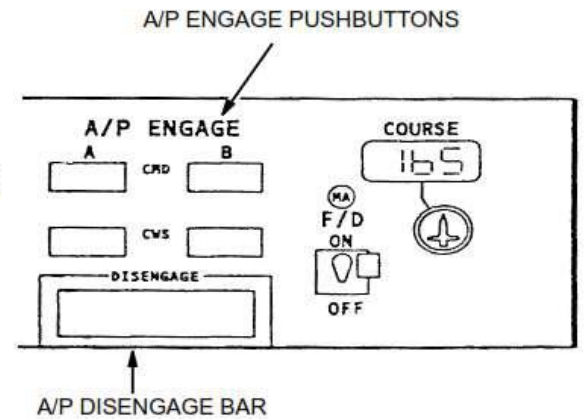

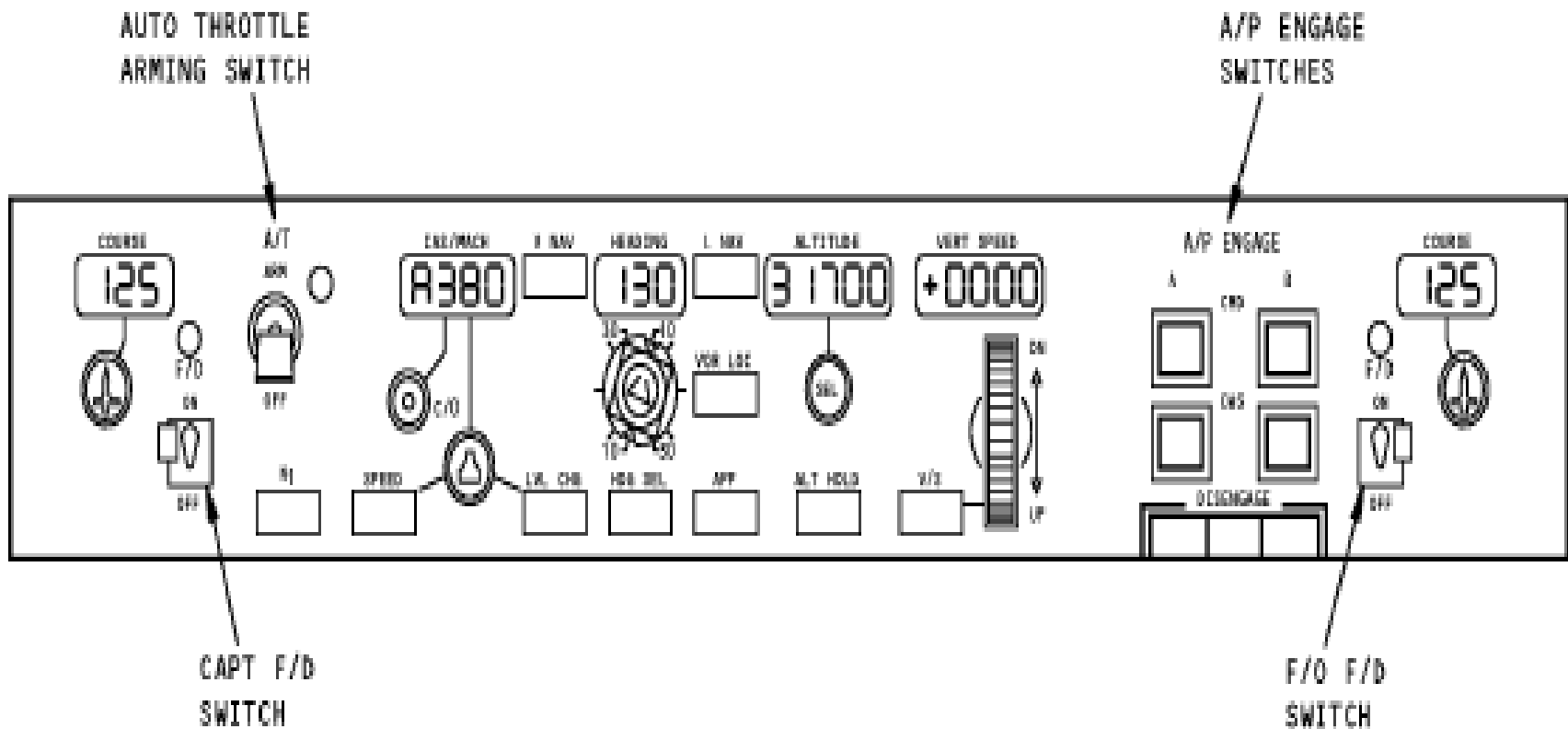

DFCS MODE CONTROL PANEL

(B)

AIRCRAFT MAINTENANCE MANUAL

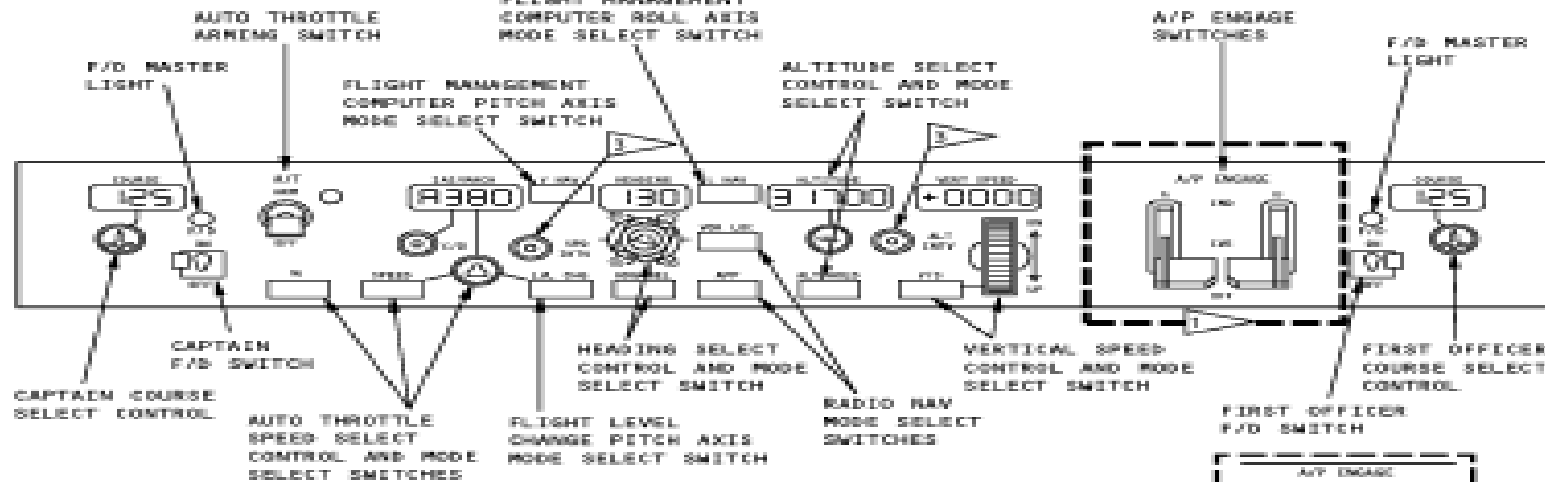

MODE CONTROL PANEL (EXAMPLE)

(D)

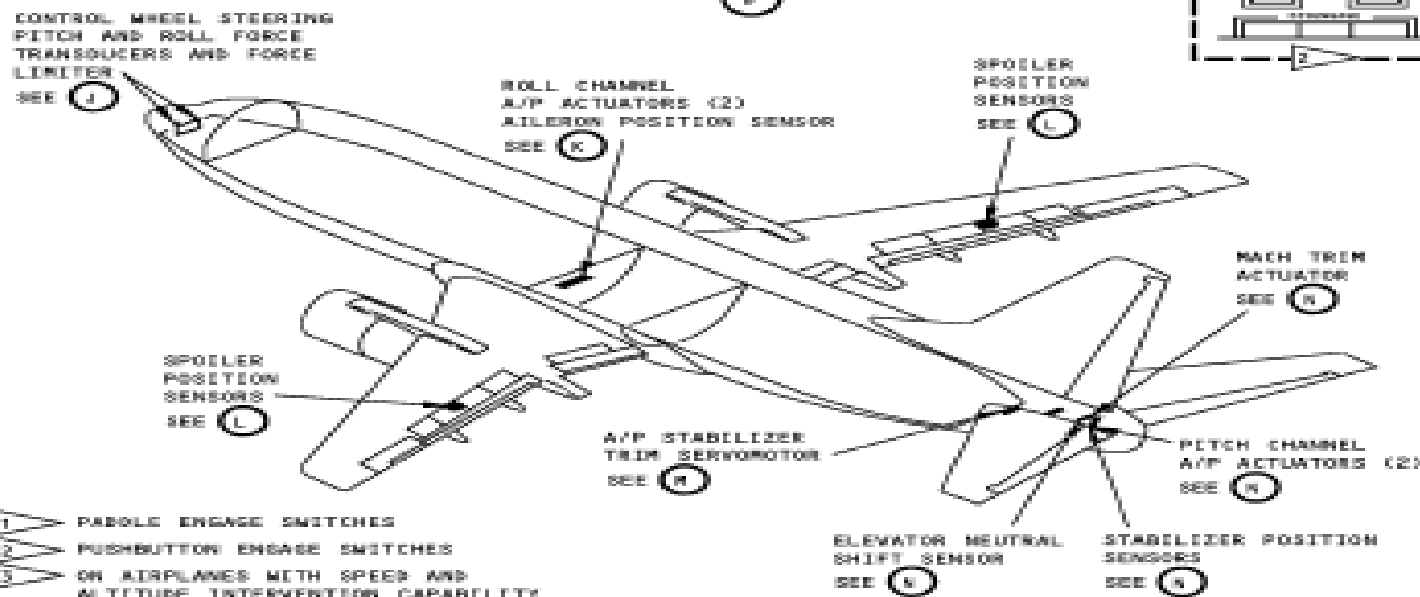

DFCS - Component Location
Figure 1 (Sheet 2 of 6)/22-11-01-990-801

ADC (AIR DATA COMPUTER)

AIRCRAFT MAINTENANCE MANUAL

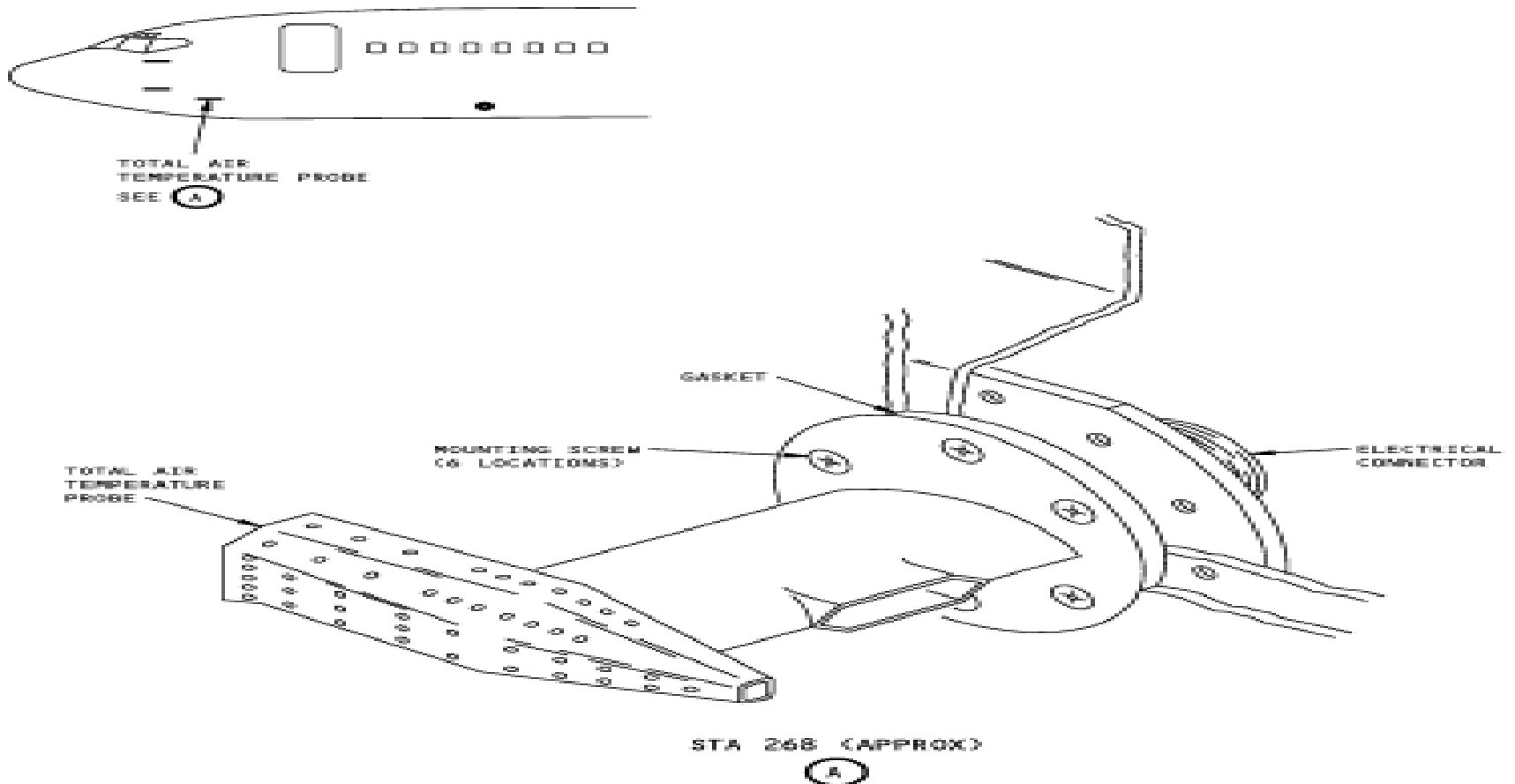

140056 59004-1000055_V1

Total Air Temperature Probe - Installation
Figure 401 (Sheet 1 of 2) 34-12-31-990-501

VOR/ILS

Este sistema permite aproximarse o aterrizar en condiciones de baja visibilidad

AIRCRAFT MAINTENANCE MANUAL

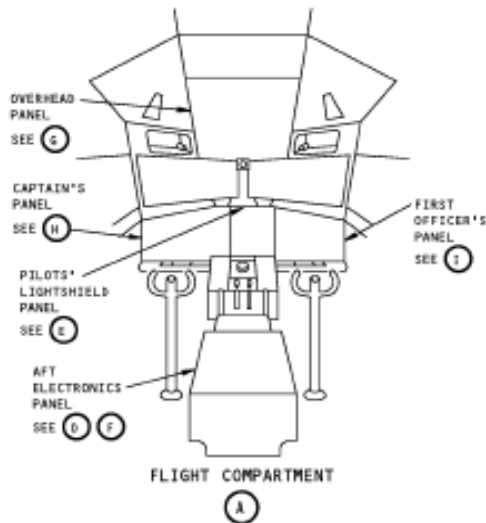
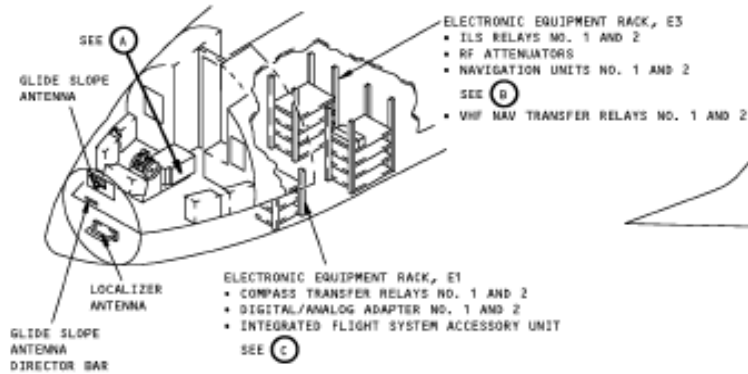

VOR/ILS Navigation System Component Location
Figure 1 (Sheet 1 of 10/34-31-02-990-801)

1380510 500041234202_V1

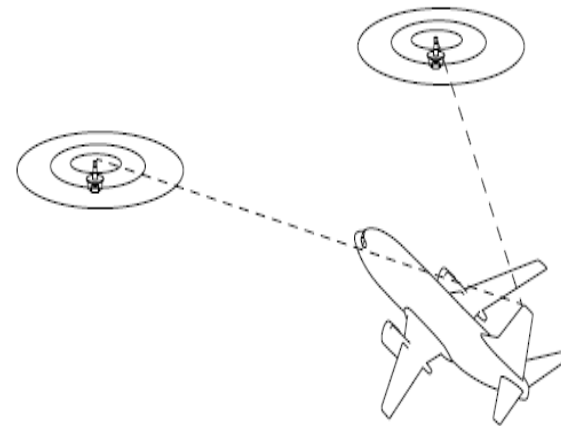

VHF OMNIDIRECTIONAL RANGING

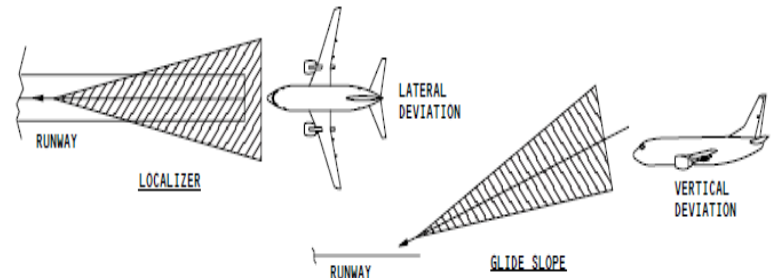

INSTRUMENT LANDING

VHF OMNIDIRECTIONAL RANGING/INSTRUMENT LANDING NAVIGATION SYSTEM - INTRODUCTION

EFFECTIVITY
FS003

34-31-CC

- 3 -

FLIGHTSAFETYBOEING PROPRIETARY(c) All rights reserved - See title page for details

LOCALIZACIÓN DE LOS COMPONENTES DEL ILS/VOR

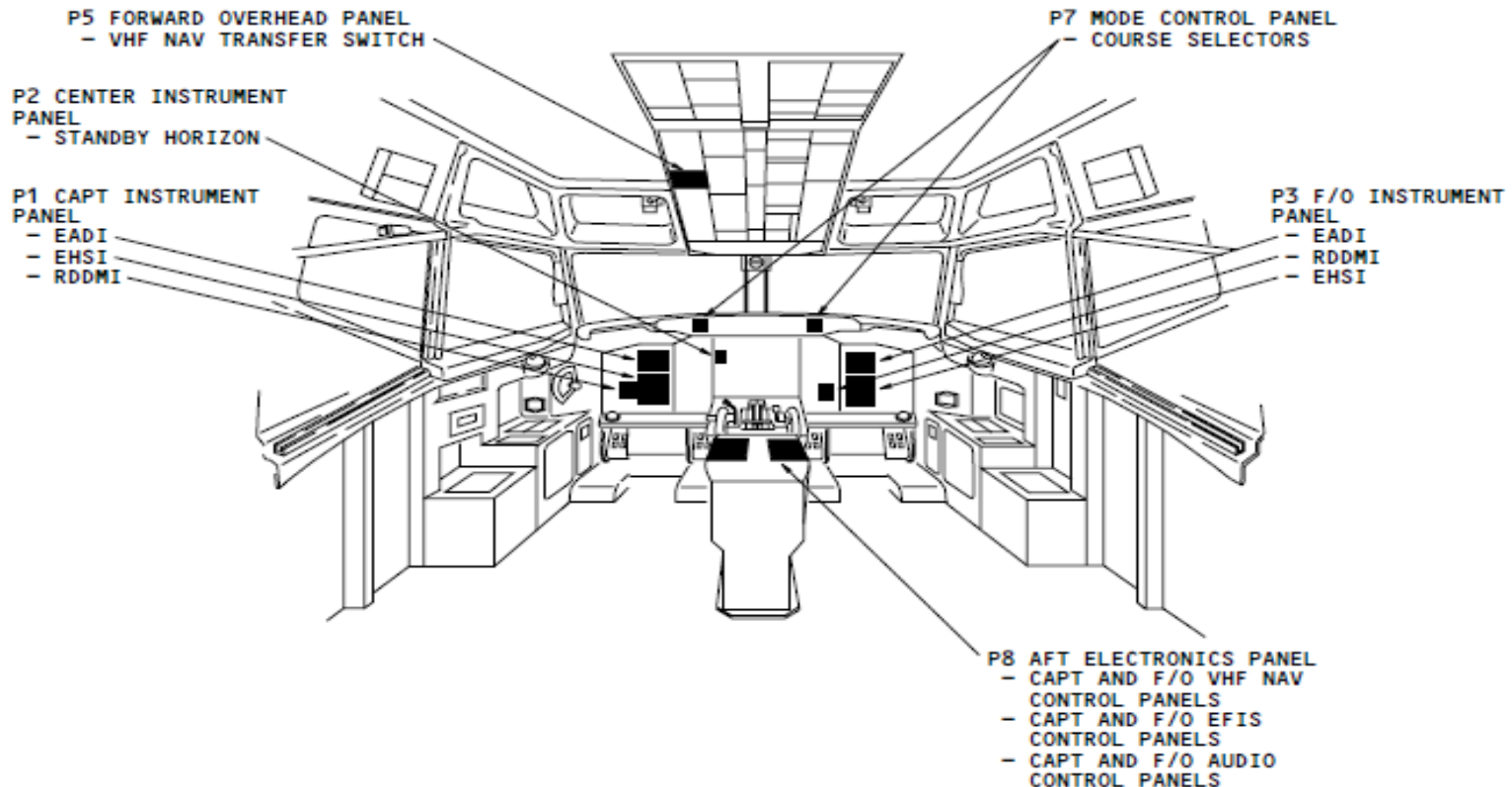

VOR/ILS NAVIGATION SYSTEM - FLIGHT COMPARTMENT COMPONENT LOCATION

EFFECTIVITY
FS003

34-31-CC

AUTOHROTTLE

- Es un sistema en el cual consiste de:
- 1 computadora digital
- Autothrottle engage switch en despegue y en aterrizaje
- 2 ángulos de palanca de potencia (PLA) synchros está montado en la caja de control de combustible del motor.

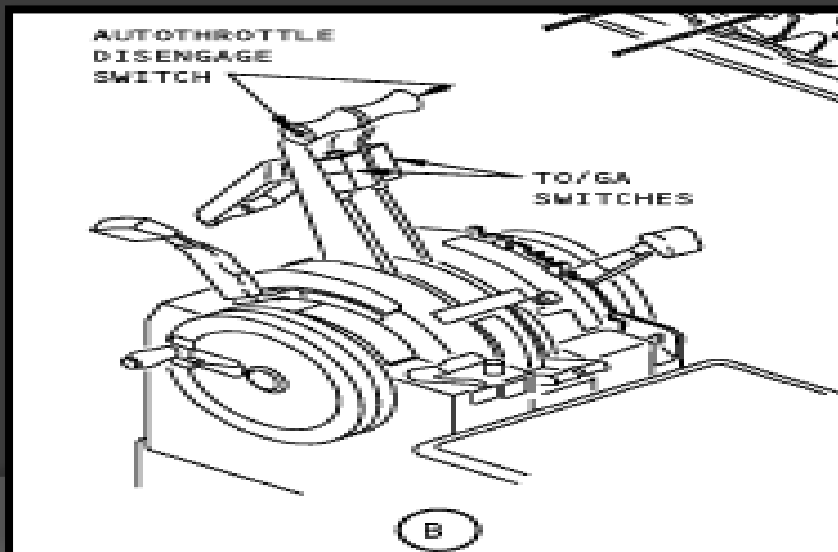

LOCALIZACIÓN DEL AUTO THROTTLE

AIRCRAFT MAINTENANCE MANUAL

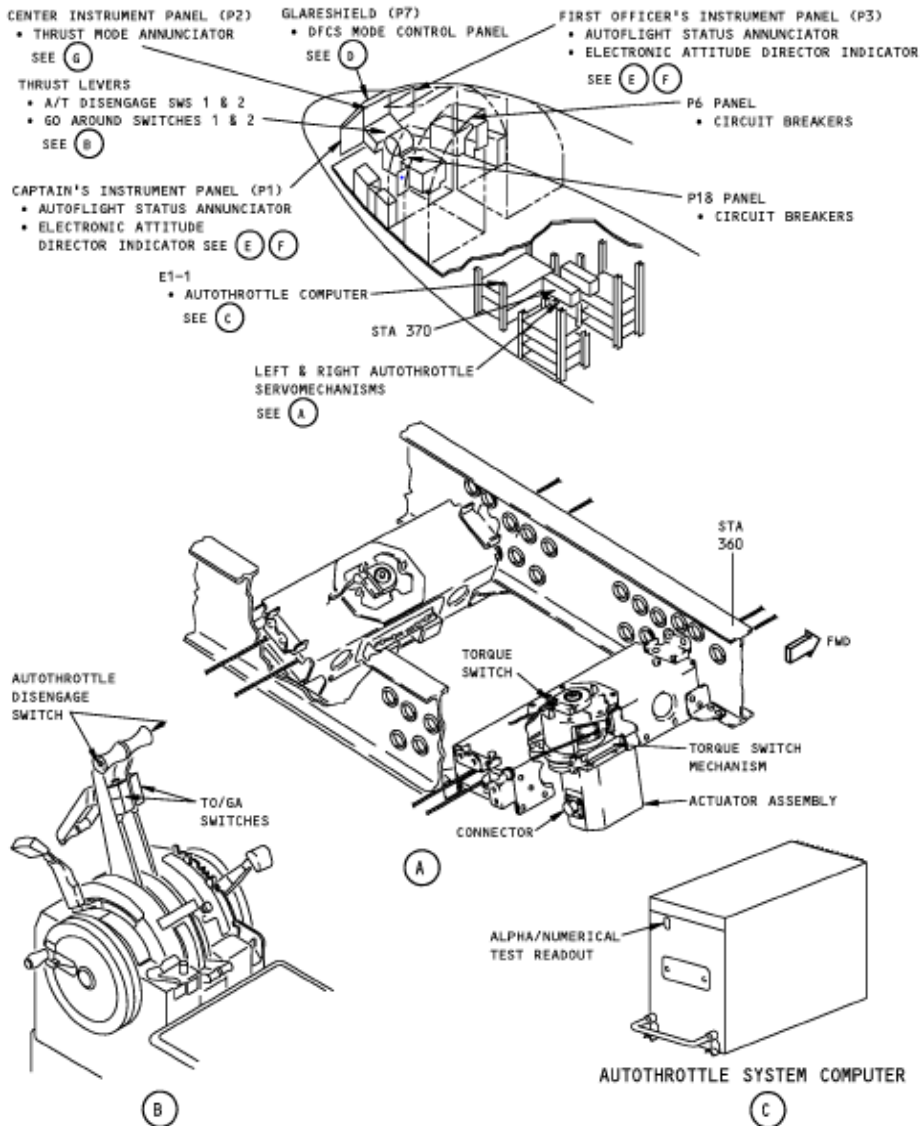

Autothrottle System - Component Location
Figure 1 (Sheet 1 of 6)/22-31-00-990-801

1357310 S00041211605_V1

AIRCRAFT MAINTENANCE MANUAL

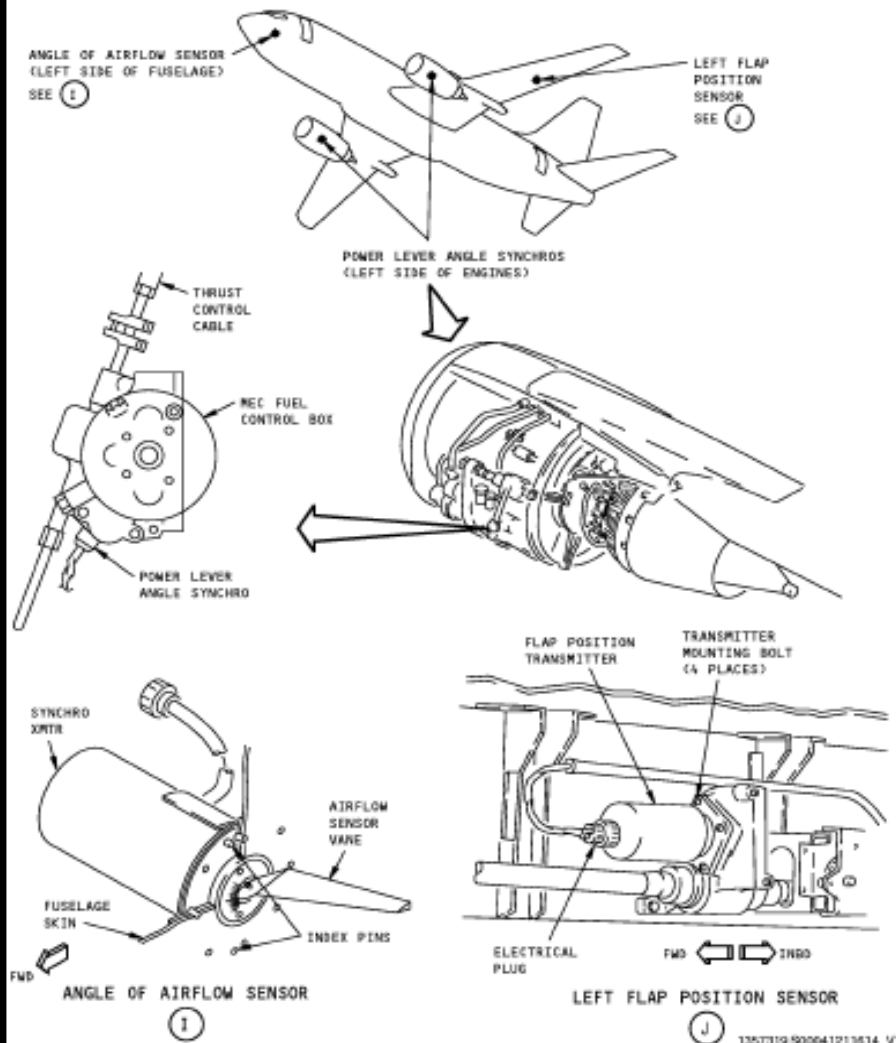

Autothrottle System - Component Location
Figure 1 (Sheet 6 of 6)/22-31-00-990-801

1357310 S00041211614_V1



GRACIAS