



ESPE-L

INGENIERÍA AUTOMOTRIZ

**PROYECTO PREVIO A LA OBTENCIÓN DEL TÍTULO DE INGENIERO
AUTOMOTRIZ**

**MANOSALVAS FLORES JAIME ANDRÉS
SOLÍS SANTAMARÍA JAVIER MILTON**

Latacunga, Agosto 2013



DISEÑO Y CONSTRUCCIÓN DE UNA SEBRADORA DE MAÍZ Y UN SISTEMA DE RIEGO A SER IMPLEMENTADO EN EL PROTOTIPO DE TRACTOR AGRÍCOLA MONOPLAZA A DIÉSEL



INTRODUCCIÓN

Consiste en dos herramientas puestas al servicio de la producción agrícola ofreciendo la oportunidad de reducir el esfuerzo físico del agricultor y optimizar tiempo en el sembrado de maíz como el regadío del mismo.



OBJETIVOS

OBJETIVO GENERAL:

- Diseñar, construir e implementar una sembradora de maíz.
- Diseñar, construir e implementar un sistema de riego.



OBJETIVOS

OBJETIVOS ESPECÍFICOS

- Determinar el tipo de sembradora de maíz para los campos de centro del país.
- Determinar el tipo de regadío que se necesita para el cultivo del maíz.
- Seleccionar la bomba adecuada para el sistema de riego.
- Seleccionar materiales necesarios para la construcción de la sembradora de maíz.
- Seleccionar materiales necesarios para la construcción del sistema de riego.



EQUIPOS PARA EL SEMBRADO DE MAÍZ

En línea o a chorrillo



A Golpes



Mono grano
Neumática





SEMBRADORA MONO GRANO NEUMÁTICA

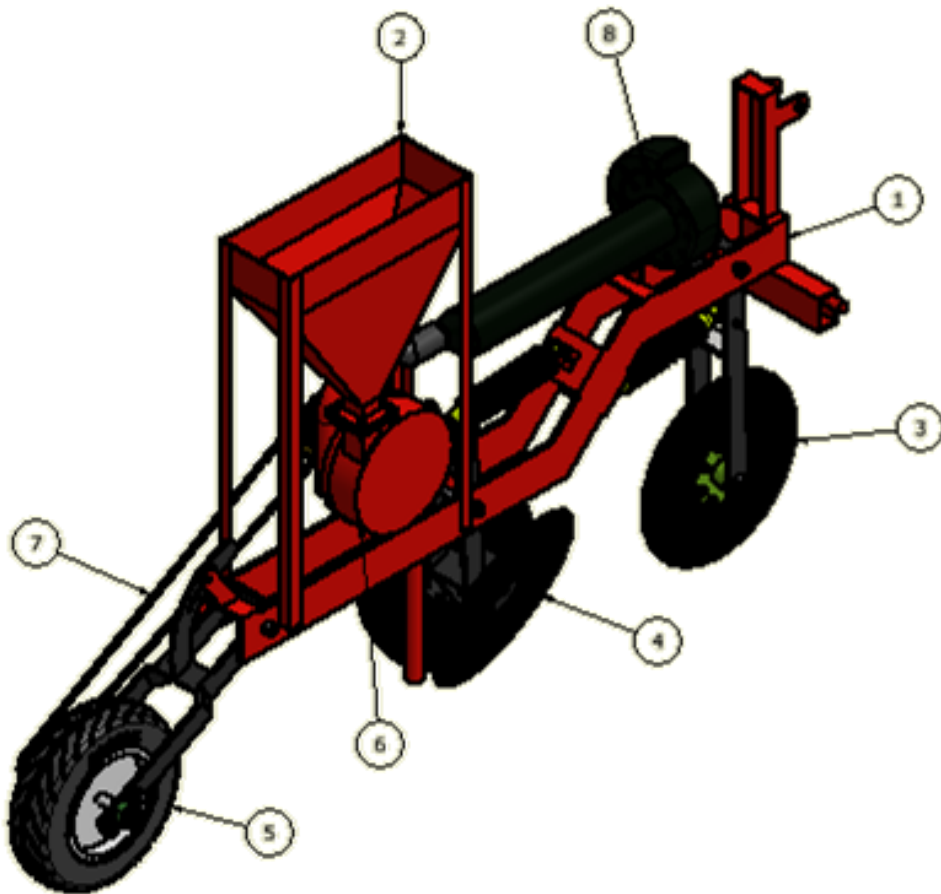

- (1) Chasis
- (2) Tolva
- (3) Cuchilla de corte
- (4) Abre surcos
- (5) Rueda compactadora
- (6) Dosificador
- (7) Trasmisión
- (8) Electro ventilador



SEMBRADORA MONO GRANO NEUMÁTICA

Parámetros de diseño

Distancia entre surcos	75 a 120 cm
Distancia entre semillas	10 a 15 cm
Profundidad de sembrado	2 a 4 cm
Tipo de suelo	Cangagua
Capacidad del equipo	20 kg.



DOSIFICADOR NEUMÁTICO

Disco de alveolos

$$F_A = \frac{T}{\mu D} = 22,2N$$

$$F = \mu_s N$$

$$F1 = F3 = 0.54 \times 22.2 = 11,9 \text{ Newton}$$

$$F2 = 0.9 \times 22.2 = 19.98 \text{ Newton}$$

$$M = 3.86 \text{ Nm}$$

$$V = \omega \cdot R = 0,36 \frac{m}{s} = 13.35 \text{ rpm}$$

$$P = M \cdot \omega = 5,41 \text{ Watts} = 0,20 \text{ HP}$$

$$K = \frac{2 \cdot \pi \cdot R}{d} = 20$$

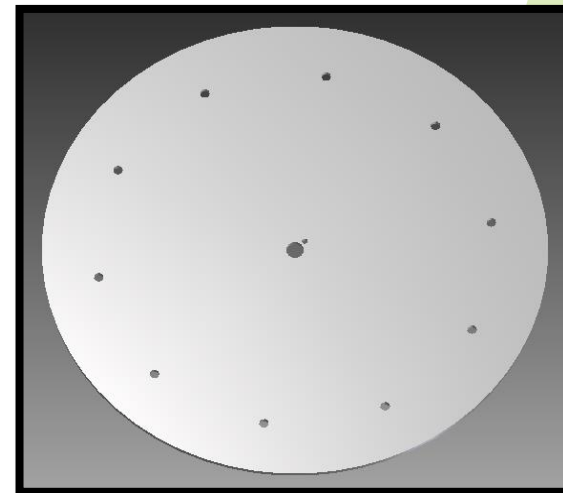
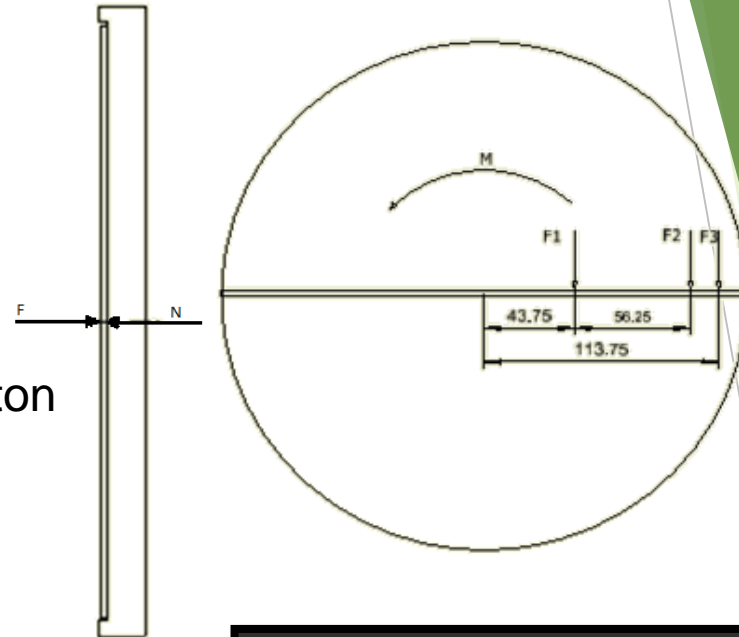



DOSIFICADOR NEUMÁTICO

Selección de la transmisión

PARÁMETROS DE DISEÑO	
Velocidad de entrada	26.7 rpm
Velocidad de salida	13.35 rpm
Arrastrado por un tractor a diésel	Carga ligera
Potencia necesaria	0.2 Hp

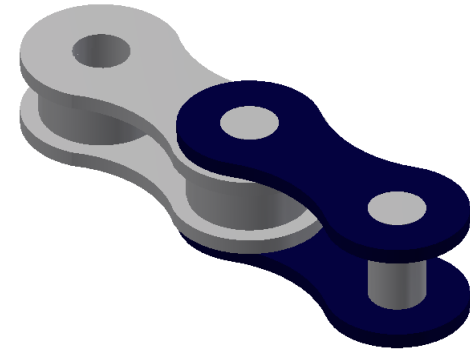

$$P_d = P \cdot FS = 0,24hp$$

$$i = \frac{V_{entrada}}{V_{salida}} = 2$$

$$N_2 = N_1 \cdot i = 38$$

TABLA 7-5 Capacidades en catenas de fierro - Cadena simple de eslabos número 40

Núm de eslabos	0.500 pulgadas de paso										Velocidad máxima de giro de la catena, revol/min														
	10	25	50	100	180	200	300	500	700	900	1000	1300	1400	1600	1800	2100	2500	3000	3500	4000	5000	6000	7000	8000	9000
11	0.06	0.14	0.27	0.52	0.91	1.00	1.48	2.42	3.34	4.25	4.70	5.80	6.49	5.57	4.66	3.70	2.85	2.17	1.72	1.41	1.01	0.77	0.61	0.50	0.00
12	0.06	0.15	0.29	0.56	0.99	1.00	1.61	2.64	3.64	4.64	5.13	6.11	7.09	6.34	5.31	4.22	3.25	2.47	1.96	1.60	1.15	0.87	0.69	0.57	0.00
13	0.07	0.16	0.31	0.61	1.07	1.19	1.75	2.86	3.95	5.05	5.56	6.62	7.68	7.15	5.99	4.76	3.66	2.79	2.21	1.81	1.29	0.98	0.78	0.00	0.00
14	0.07	0.17	0.34	0.66	1.15	1.28	1.88	3.08	4.25	5.41	5.98	7.13	8.27	7.99	6.70	5.31	4.09	3.11	2.47	2.02	1.45	1.10	0.87	0.00	0.00
15	0.08	0.19	0.36	0.70	1.24	1.37	2.02	3.30	4.53	5.80	6.41	7.64	8.86	8.86	7.43	5.89	4.54	3.45	2.74	2.24	1.60	1.22	0.97	0.00	0.00
16	0.08	0.20	0.39	0.75	1.32	1.46	2.15	3.52	4.86	6.18	6.84	8.15	9.45	9.76	8.18	6.49	5.00	3.80	3.02	2.47	1.77	1.34	1.00	0.00	0.00
17	0.09	0.21	0.41	0.80	1.40	1.55	2.29	3.74	5.16	6.57	7.27	8.66	10.04	10.69	8.96	7.11	5.48	4.17	3.31	2.71	1.94	1.47	1.00	0.00	0.00
18	0.09	0.22	0.43	0.84	1.48	1.64	2.42	3.96	5.46	6.95	7.69	9.17	10.65	11.65	9.76	7.75	5.97	4.54	3.60	2.95	2.11	1.60	1.00	0.00	0.00
19	0.10	0.23	0.46	0.89	1.57	1.73	2.56	4.18	5.77	7.34	8.12	9.66	11.22	12.64	10.59	8.40	6.47	4.92	3.91	3.20	2.29	1.60	1.00	0.00	0.00
20	0.10	0.25	0.48	0.94	1.65	1.82	2.69	4.39	6.07	7.73	8.55	10.18	11.81	13.42	11.44	9.07	6.99	5.31	4.22	3.45	2.47	1.80	1.00	0.00	0.00
21	0.11	0.26	0.51	0.98	1.73	1.91	2.83	4.61	6.37	8.11	8.98	10.69	12.40	14.10	12.30	9.76	7.52	5.72	4.54	3.71	2.65	1.80	1.00	0.00	0.00
22	0.11	0.27	0.53	1.03	1.81	2.01	2.96	4.83	6.68	8.50	9.40	11.20	12.99	14.77	13.19	10.47	8.06	6.13	4.87	3.96	2.85	1.80	1.00	0.00	0.00
23	0.12	0.28	0.56	1.08	1.90	2.10	3.10	5.05	6.98	8.89	9.83	11.71	13.58	15.44	14.10	11.19	8.62	6.55	5.20	4.26	3.05	1.80	1.00	0.00	0.00
24	0.12	0.30	0.58	1.13	1.98	2.19	3.23	5.27	7.28	9.27	10.26	12.22	14.17	16.11	15.03	11.93	9.18	6.96	5.54	4.54	3.07	1.80	1.00	0.00	0.00
25	0.13	0.31	0.60	1.17	2.06	2.28	3.36	5.49	7.59	9.66	10.69	12.73	14.76	16.78	15.98	12.68	9.76	7.43	5.89	4.82	3.00	1.80	1.00	0.00	0.00
26	0.13	0.32	0.63	1.23	2.14	2.37	3.50	5.71	7.89	10.04	11.11	13.24	15.35	17.45	16.95	13.45	10.36	7.88	6.25	5.12	3.00	1.80	1.00	0.00	0.00
28	0.14	0.35	0.67	1.31	2.31	2.55	3.77	6.15	8.50	10.82	11.97	14.26	16.53	18.79	18.94	15.03	11.57	8.80	6.99	5.72	3.00	1.80	1.00	0.00	0.00
30	0.15	0.37	0.72	1.41	2.47	2.74	4.04	6.59	9.11	11.59	12.82	15.28	17.71	20.14	21.01	16.67	12.84	9.76	7.75	6.34	3.00	1.80	1.00	0.00	0.00
32	0.16	0.40	0.77	1.50	2.64	2.92	4.31	7.03	9.71	12.38	13.68	16.30	18.89	21.48	23.14	18.37	14.14	10.76	8.54	1.41	3.00	1.80	1.00	0.00	0.00
35	0.18	0.43	0.84	1.64	2.88	3.19	4.71	7.69	10.62	13.52	14.96	17.82	20.67	23.49	26.30	21.01	16.17	12.30	9.76	0.00	3.00	1.80	1.00	0.00	0.00
40	0.21	0.50	0.96	1.87	3.30	3.65	5.38	8.79	12.14	15.45	17.10	20.37	23.62	26.85	30.06	25.67	19.76	15.03	0.00	3.00	1.80	1.00	1.00	0.00	0.00
45	0.23	0.56	1.08	2.11	3.71	4.10	6.08	9.89	13.66	17.39	19.24	22.92	26.57	30.30	33.82	30.63	23.38	5.53	0.00	3.00	1.80	1.00	1.00	0.00	0.00

Tipo A: Lubricación manual o por graso
 Tipo B: Lubricación en baño o con aceite
 Tipo C: Lubricación con chorro de agua

Fuente: American Chain Association, Naples, FL



DOSIFICADOR NEUMÁTICO

Selección de la transmisión

$$D_1 = \frac{p}{\sin(180^\circ/N_1)} = 3 \text{ pulg}$$

$$D_2 = \frac{p}{\sin(180^\circ/N_2)} = 6 \text{ pulg}$$

$$L = 2C + \frac{N_2 + N_1}{2} + \frac{(N_2 - N_1)^2}{4C\pi^2} = 148 \text{ pasos}$$

$$\theta_1 = 180^\circ - 2 \sin^{-1}[(D_2 - D_1)/2C] = 174^\circ$$

$$\theta_2 = 180^\circ + 2 \sin^{-1}[(D_2 - D_1)/2C] = 185^\circ$$

Paso	Cadena número 40, 0.5 pulgada de paso
Longitud	148 pasos = 148(05)= 74 pulgada
Distancia entre centros	C= 29.84 pulgadas
Catarinas	Hilera simple, número 40, ½ pulgada
Pequeña	19 dientes, D=3 pulgadas
Grande	38 dientes, D 6 pulgadas





DOSIFICADOR NEUMÁTICO

Selección del electro ventilador

VELOCIDADES TERMINALES DE VARIOS PRODUCTOS		
Producto	Pies/minuto	Metros/minuto
Arroz paddy	1.350	491
Arroz Blanco	1.200	365
Cáscara de granos	1.000 (?)	300
Maíz	2.200	670

$$Q = v \times A = 0.045 \text{ m}^3/\text{s}$$

Electro Ventilador Centrifugo

Turbina rpm 1800

Motor rpm 1800

Motor 186.42 watts

Peso aprox.(kg) 3

Caudal máximo(m3/s) 0.55





SEMBRADORA MONO GRANO NEUMÁTICA

Diseño de la Tolva

$$\rho = \frac{1}{D \times d} = 100,000 \text{ semillas/ha}$$

ASTM A – 36

Espesor 2 mm

$$F_1 = 196 \text{ N}$$

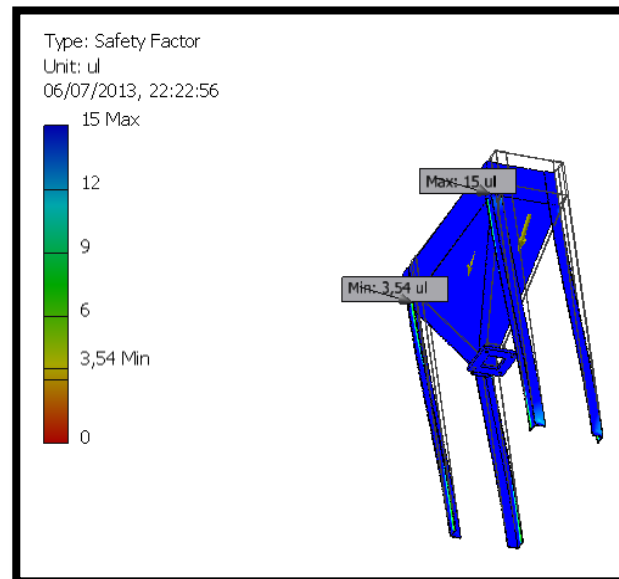
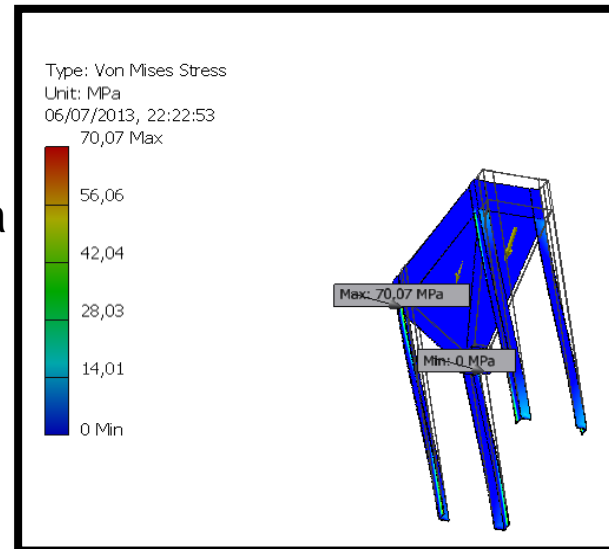
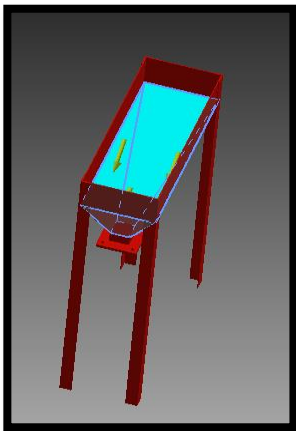



SEMBRADORA MONO GRANO NEUMÁTICA

Fuerzas que actúan

$$S_c = n \cdot a \cdot p = 1,5cm^2$$

$$F_c = \mu \cdot S = 11,7 N$$

$$R_c = F + fr = 1066,46 N$$

$$S_s = n \cdot a \cdot p = 20cm^2$$

$$F_s = \mu \cdot S = 156 N$$

$$R_s = F + fr = 1210,76 N$$

$$N = 1506,8 [N]$$

$$F = 3181,3 [N]$$

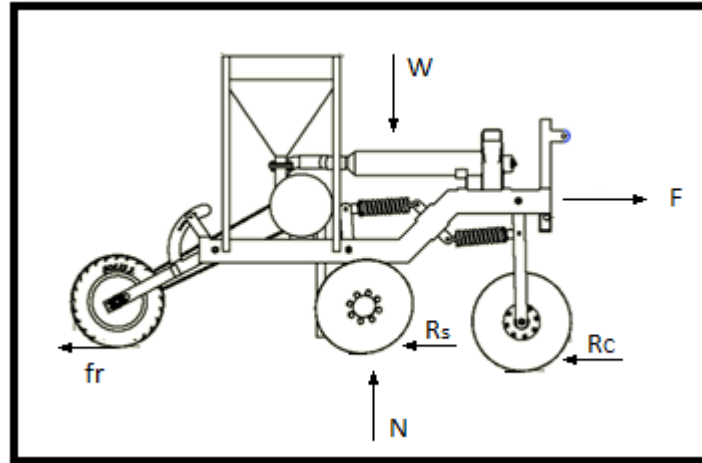

$$P = F \times V = 3531,24Watts = 5HP$$



SEMBRADORA MONO GRANO NEUMÁTICA

Base del Abre Surcos en V

ASTM A – 36

Espesor 9 mm

$F_s = 1210,76 N$

$F = 1727.2 N$

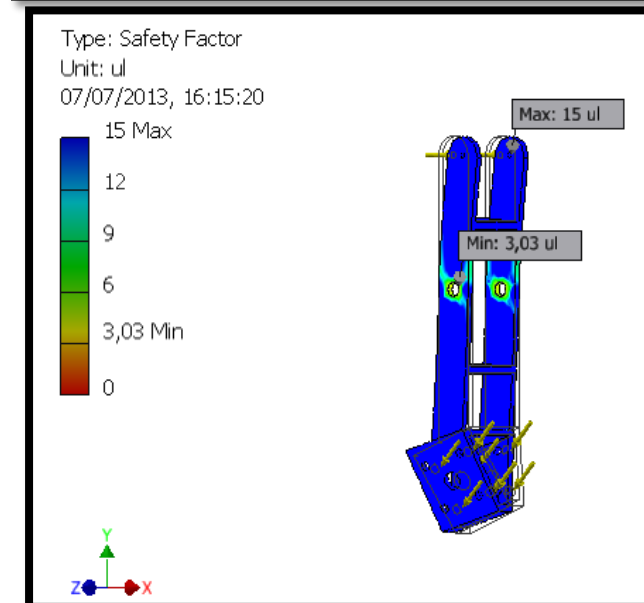
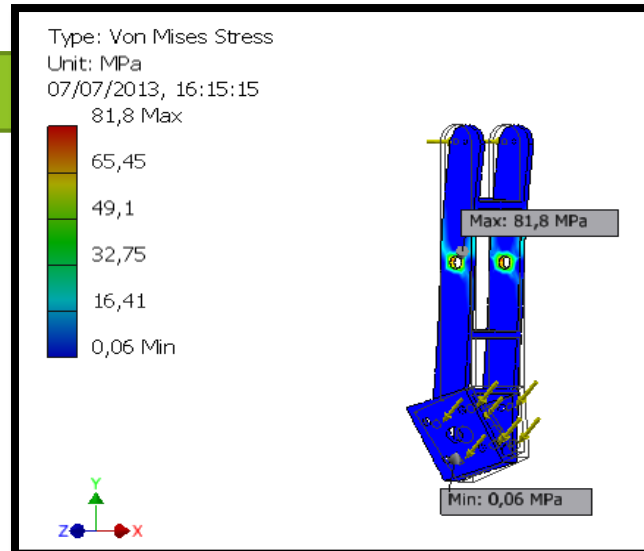
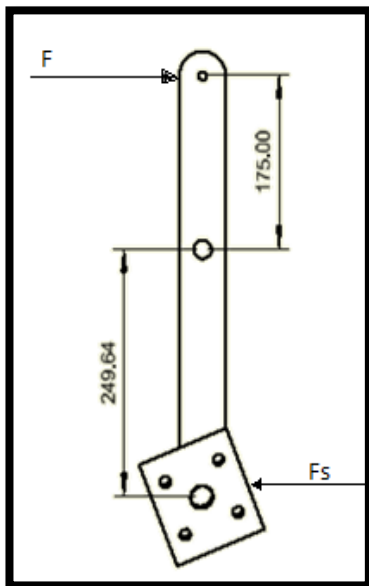



SEMBRADORA MONO GRANO NEUMÁTICA

Selección del amortiguador

Aplicación	Modelo	Especificaciones	Dimensiones
Wagner	monoshock-para-dakar-200zttskua	Longitud total	365 mm
		Distancia entre ejes	335 mm
		Diámetro buje superior	10 mm
		Diámetro buje inferior	10 mm
		Ajustable	5 posiciones
		Carga máx. [N]	1750





SEMBRADORA MONO GRANO NEUMÁTICA

Base de la cuchilla de corte

ASTM A – 36

Espesor 9 mm

$$F_C = 1066,46 N$$

$$F = 1727.2N$$

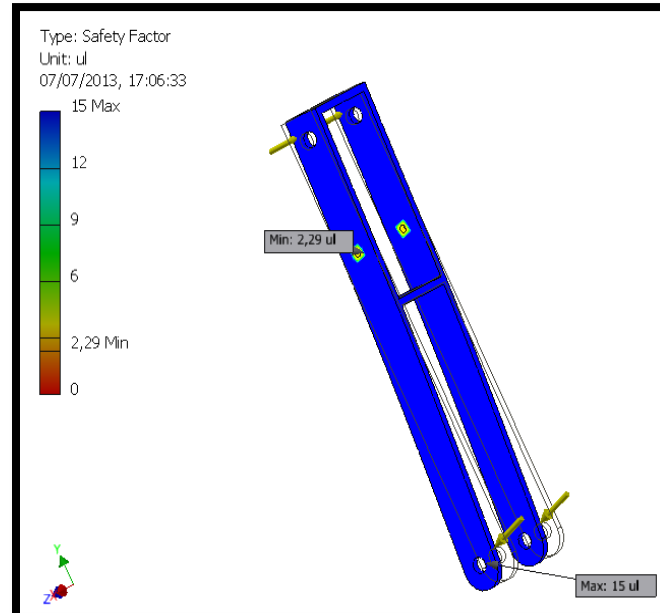
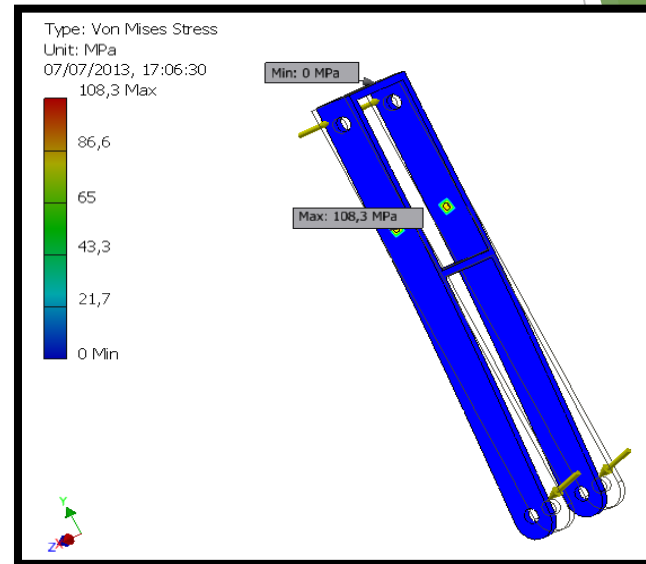
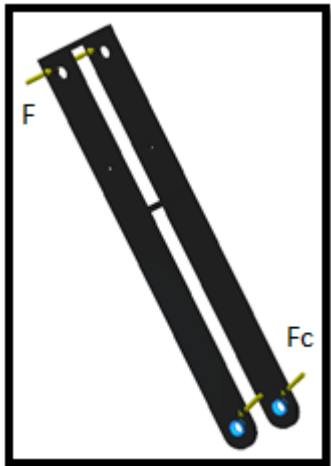



SEMBRADORA MONO GRANO NEUMÁTICA

Base de la rueda compactadora

ASTM A – 36

Espesor 9 mm

$F = 1314.2N$

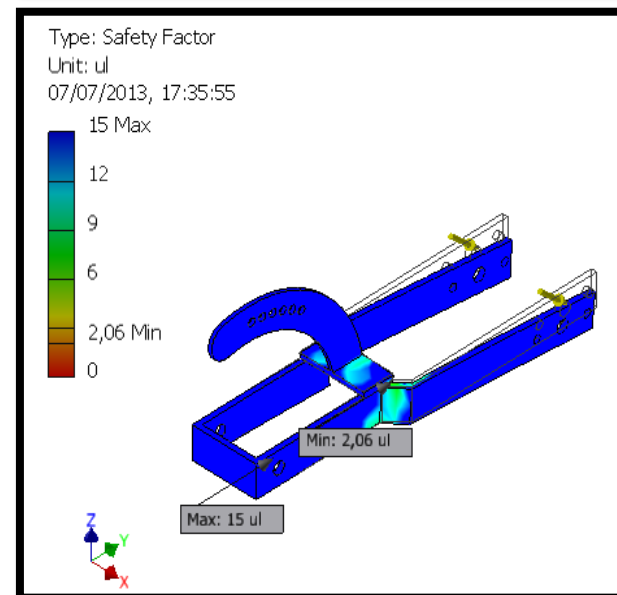
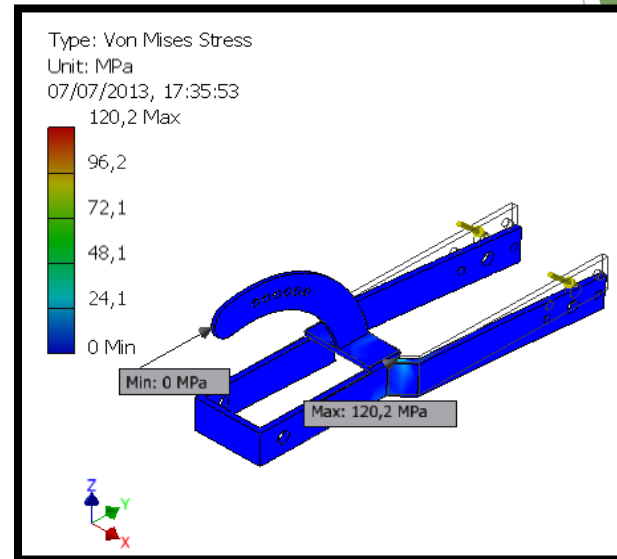
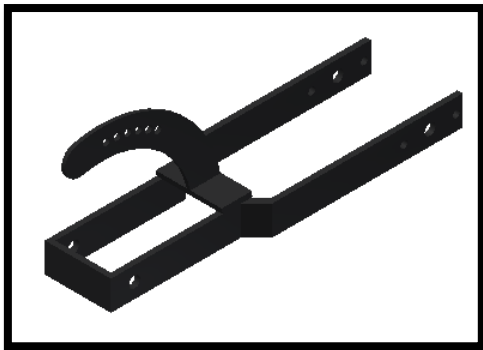









SEMBRADORA MONO GRANO NEUMÁTICA

Selección de la rueda compactadora

$$W = 133.6 \text{ Kg.}$$

		Nomenclatura	Número de Lonas	Presión de Aire				
200	50	-	2	2,50	60	20	75	Rodillos
260	85	3.00-4	4	2,50	75	20	200	Rodillos
280	90	4.10-4	4	2,50	75	20	250	Rodillos
380	90	3.50-8	4	3,00	75	20 - 25	175	Rodillos
400	105	4.00-8	2	2,00	75	20 - 25	175	Rodillos



SEMBRADORA MONO GRANO NEUMÁTICA

Chasis

ASTM A – 36

Espesor 9 mm

$$F_1 = 3181,3N$$

$$F_2 = 1314,2N$$

$$F_3 = 1727,2N$$

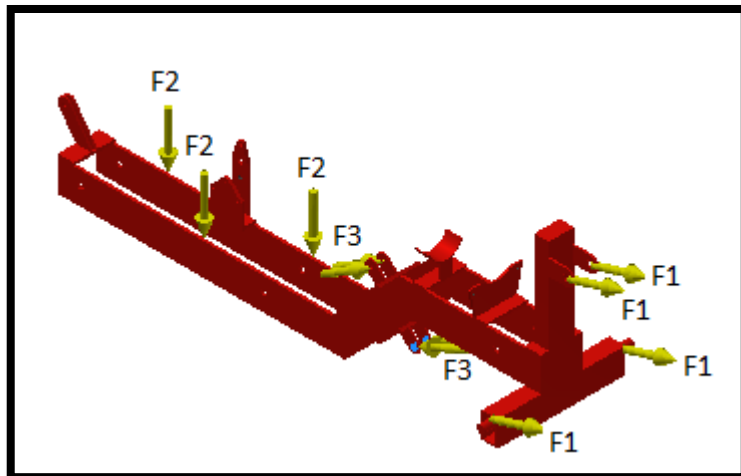

Type: Von Mises Stress

Unit: MPa

07/07/2013, 18:03:31

54,69 Max

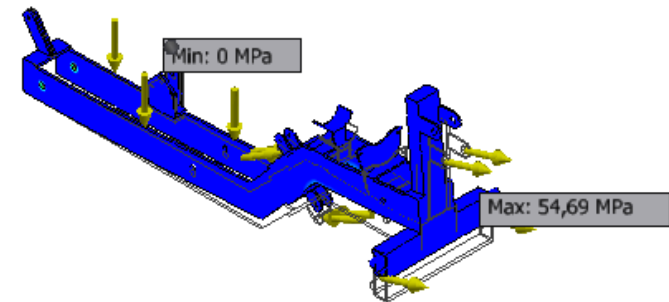
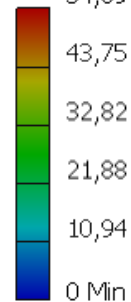

Type: Safety Factor

Unit: ul

07/07/2013, 18:03:35

15 Max

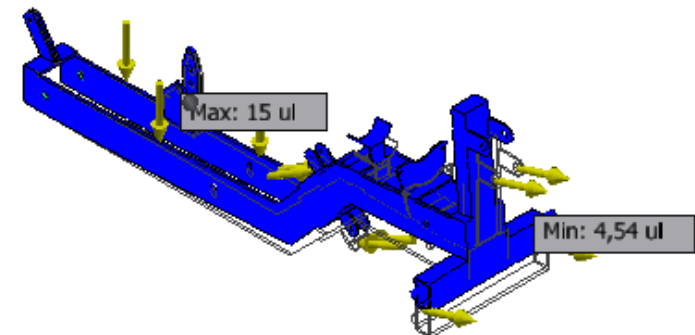
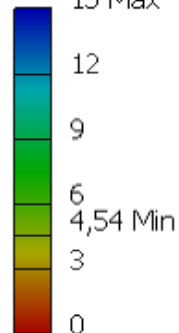



SEMBRADORA MONO GRANO NEUMÁTICA

Construcción





SEMBRADORA MONO GRANO NEUMÁTICA

Resultados

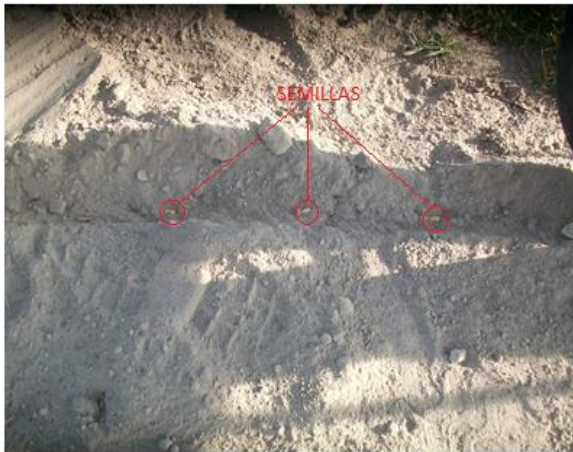



REGADÍO DEL MAÍZ



Riego por Superficie



Riego por Aspersión



Riego Localizado



SISTEMA DE RIEGO POR ASPERSIÓN

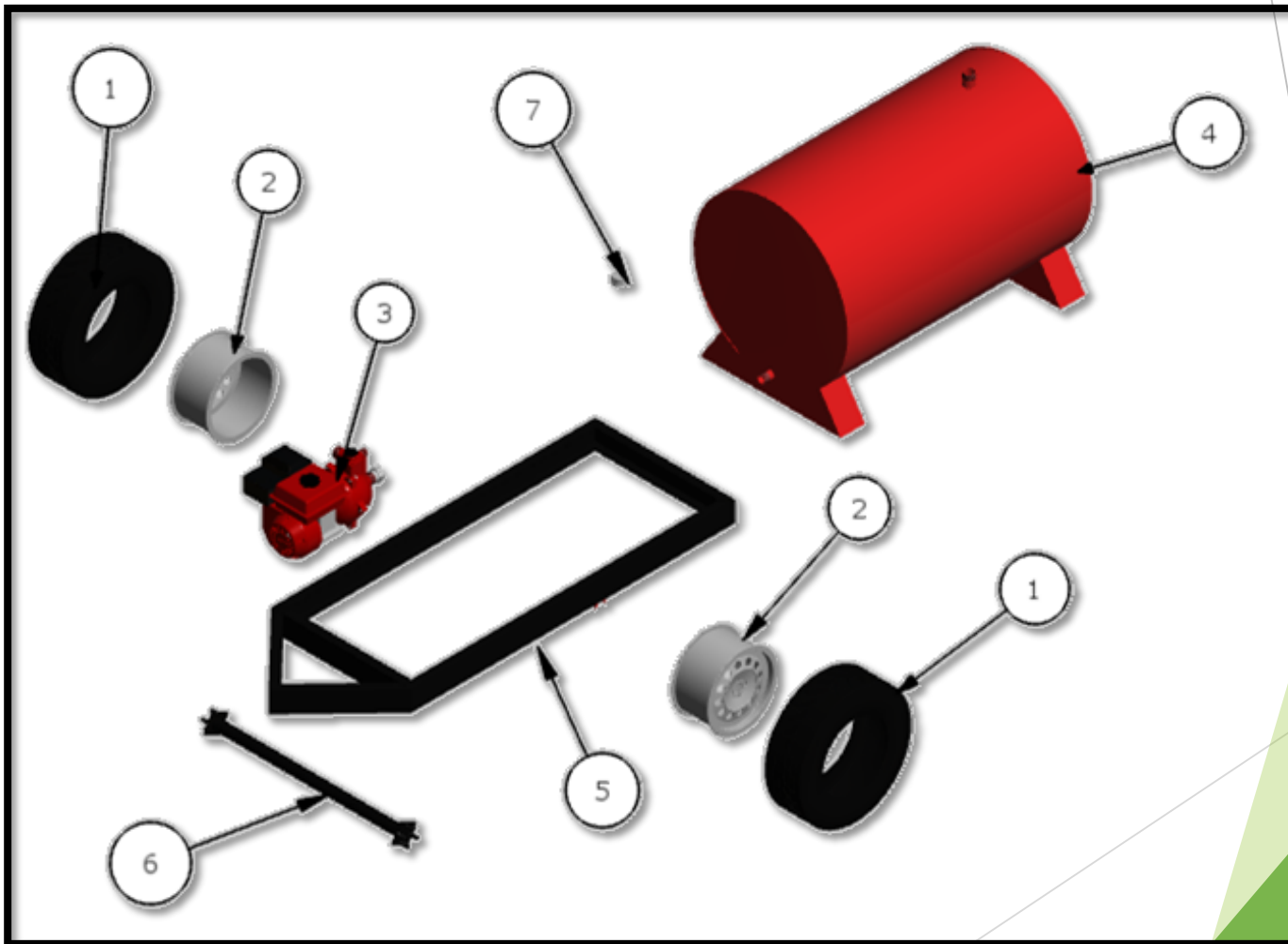



SISTEMA DE RIEGO POR ASPERSIÓN



BOMBA
DE AGUA





SISTEMA DE RIEGO POR ASPERSIÓN

Elementos Diseñados:

Tanque reservorio de agua

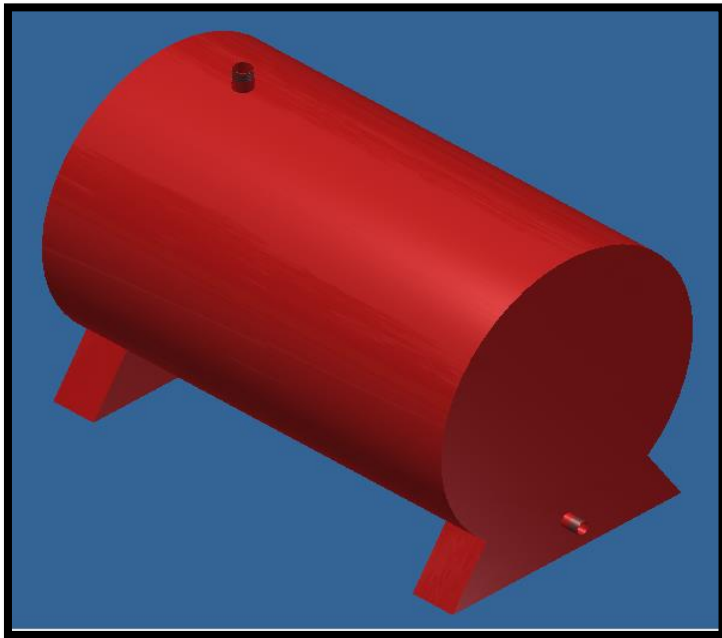

Parámetros:

- $D=785\text{mm}$
- $L=1245\text{mm}$
- $V=603\text{Lt.}$
- ASTM A-36
- Masa
- $\text{Espesor}=2\text{mm}$



SISTEMA DE RIEGO POR ASPERSIÓN

Elementos Diseñados:

Tanque reservorio de agua

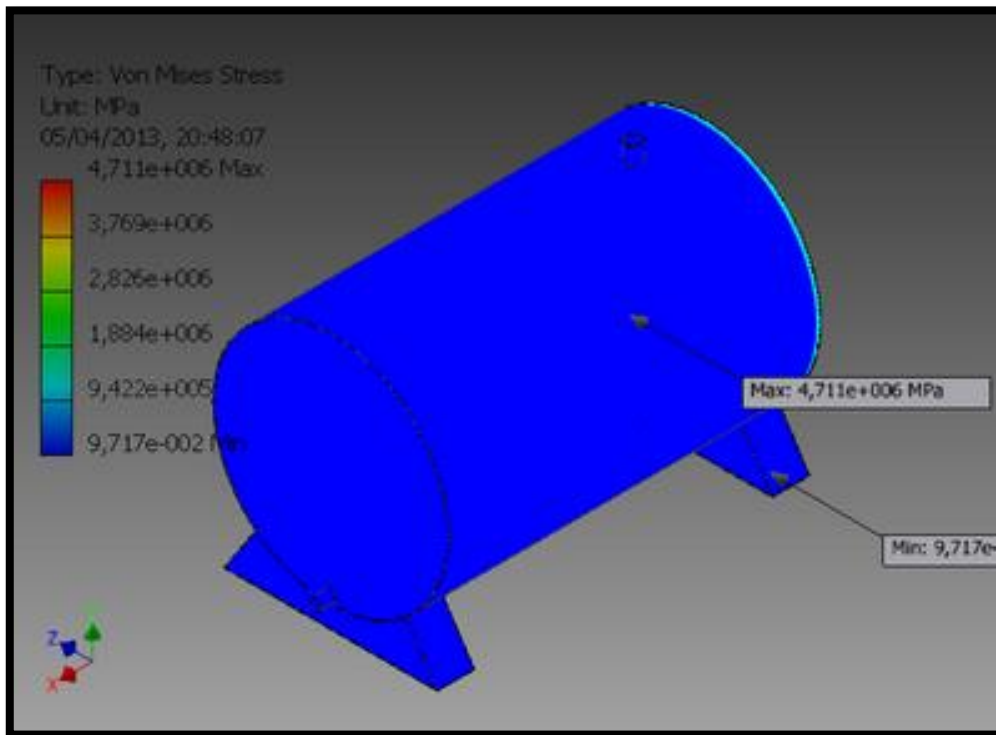

V
O
N

M
I
S
E
S



SISTEMA DE RIEGO POR ASPERSIÓN

Elementos Diseñados:

Tanque reservorio de agua

F
A
C
T
O
R

D
E

S
E
G
U
R
I
D
A
D

$$= S_y / \sigma' = 5$$

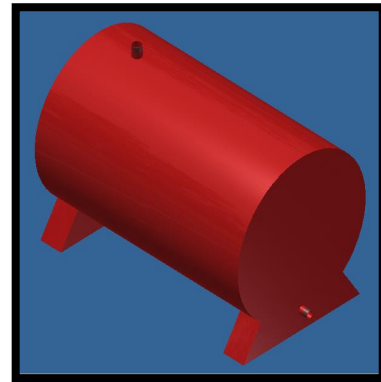



SISTEMA DE RIEGO POR ASPERSIÓN

Elementos Diseñados:

BASTIDOR

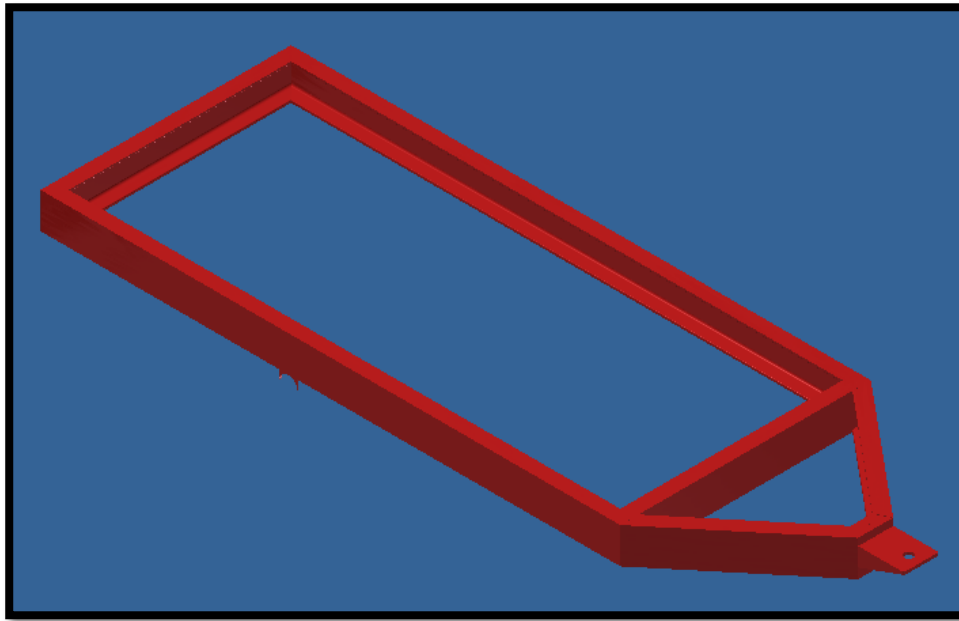

Parámetros:

- Material
- Masa
- Peso



SISTEMA DE RIEGO POR ASPERSIÓN

Elementos Diseñados:

BASTIDOR

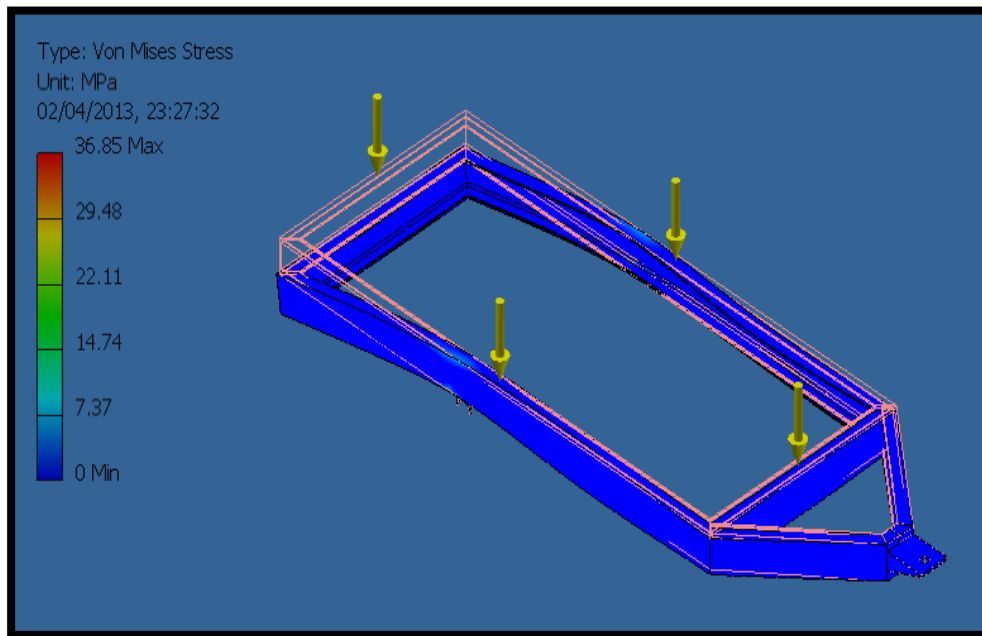

V
O
N

M
I
S
E
S



SISTEMA DE RIEGO POR ASPERSIÓN

Elementos Diseñados:

BASTIDOR

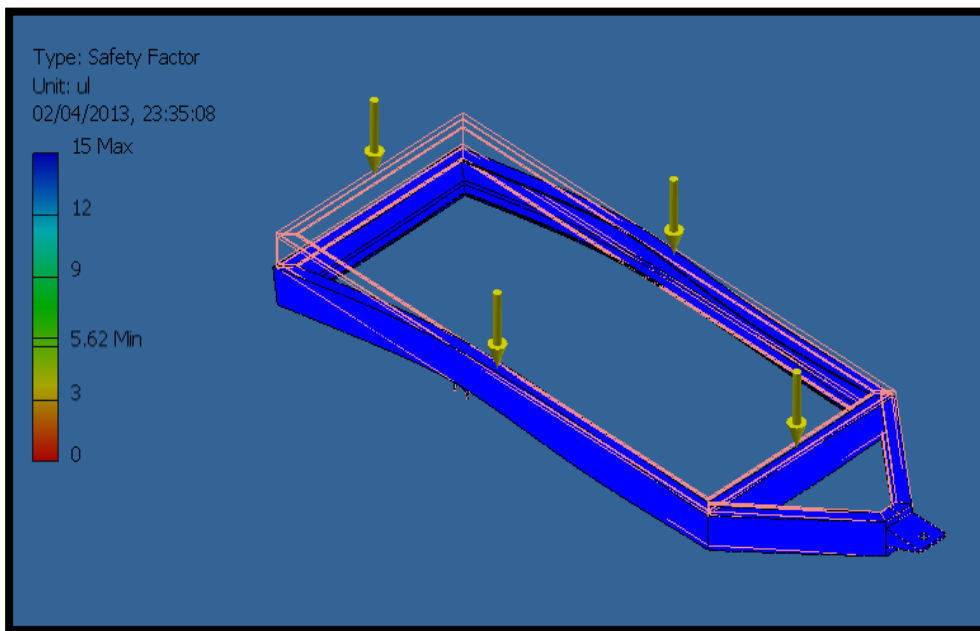

F
A
C
T
O
R

D
E

S
E
G
U
R
I
D
A
D



SISTEMA DE RIEGO POR ASPERSIÓN

Elementos Diseñados:

EJE DEL BASTIDOR

Parámetros:

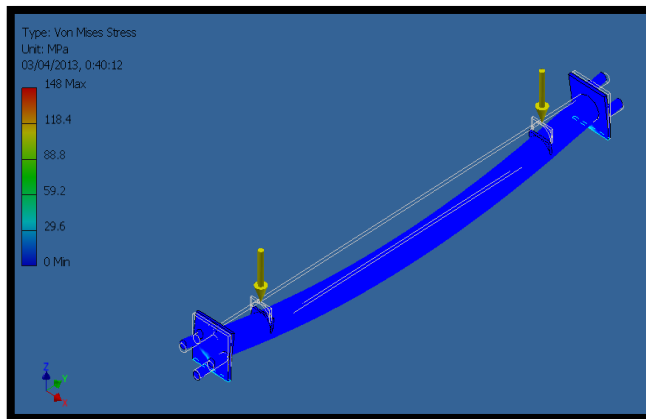

VON MISES

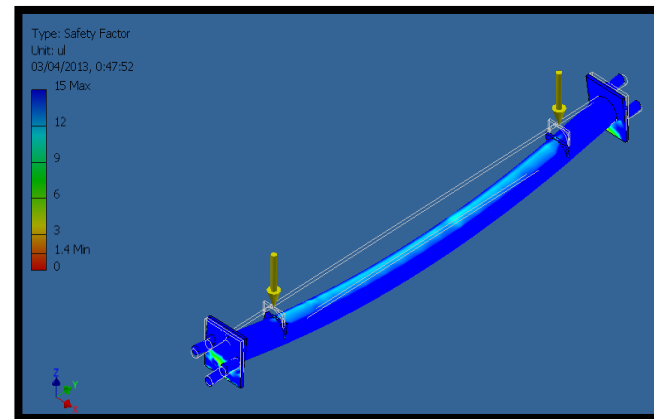

FACTOR DE SEGURIDAD



SISTEMA DE RIEGO POR ASPERSIÓN

Elementos Seleccionados:

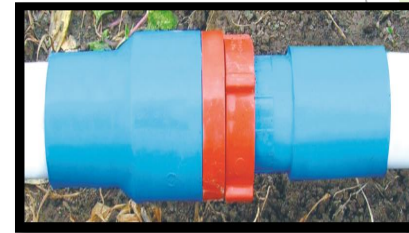
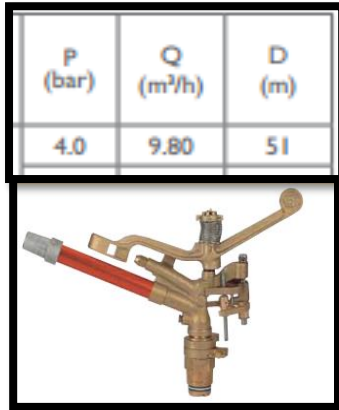

$D = 50mm$



$Pot = 1.55 HP$

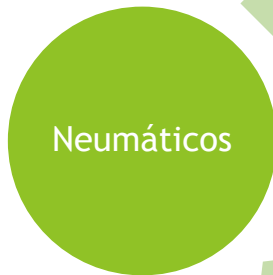



SISTEMA DE RIEGO POR ASPERSIÓN

Fuerza de arrastre del sistema de riego

$$\sum F_y = 0$$

$$N - W = 0$$

$$N = 852[kg] * 9.81[m/s^2]$$

$$N = 8358.12[N]$$

$$\sum F_x = 0$$

$$F - F_r = 0$$

$$F = 8358.12[N]$$

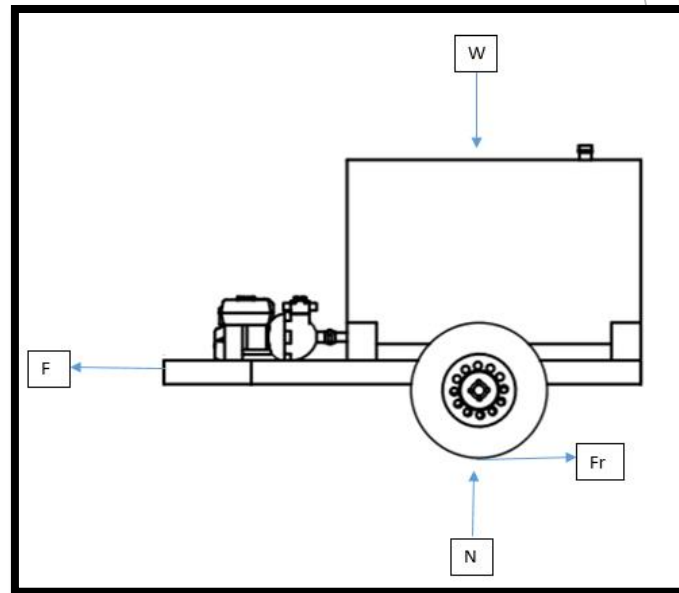

$$P = F * V$$

$$P = 9277.52Watts$$

$$P = 12.45HP$$



SISTEMA DE RIEGO POR ASPERSIÓN

CONCLUSIONES

- ❖ Se diseñó y construyó una sembradora de maíz neumática para ser implementada en el prototipo de tractor agrícola monoplaza a diésel.
- ❖ Se diseñó, seleccionó y construyó un sistema de riego para ser implementado en el prototipo de tractor agrícola monoplaza a diésel.



SISTEMA DE RIEGO POR ASPERSIÓN

RECOMENDACIONES

- ▶ El disco de corte y los discos en V son los elementos que sufrirán mayor desgaste por causa de la agresividad de la tierra y golpes producidos por rocas en el interior de la tierra se recomienda revisar periódicamente su estado.
- ▶ Antes de encender la motobomba de agua, verificar los niveles de aceite y combustible en el motor de la misma.