

PRESENTACION DEL TRABAJO DE TITULACION

FERNANDO ESTRADA

TEMA: Rediseño Internal Cabin Cockpit de
la Plataforma de Simulación del Avión
Boeing 737-800 para la Unidad de Gestión
de Tecnologías-ESPE

2015-2016

DESMONTAJE DEL OVERHEAD



DESMONTAJE DEL FRAME



DESMONTAJE DE LOS ASIENTOS

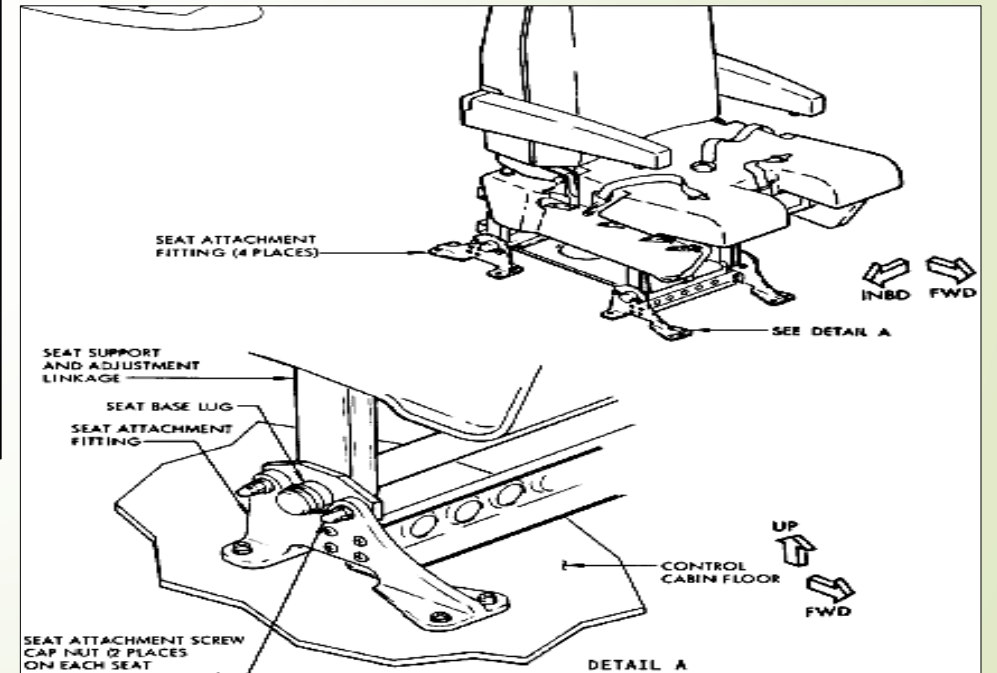

LIJADO DE LAS PAREDES INTERNAS DEL SIMULADOR



FABRICACION DEL MOLDE DE LA UPPER WINDOW



COLOCACION DE LA FIBRA DE VIDRIO



PROCESO DE SECADO



RESINA CON TALCO CHINO Y SECADO



ACABADOS PREVIOS DEL FRAME



PROCESO DE TAPIZADO



MONTAJE DEL FRAME



TRABAJO TERMINADO



PARTE DE INGRESO DE LA CABINA



TRABAJO FINALIZADO

