



ESPE

UNIVERSIDAD DE LAS FUERZAS ARMADAS
INNOVACIÓN PARA LA EXCELENCIA

DEPARTAMENTO DE ELÉCTRICA Y ELECTRÓNICA

CARRERA DE INGENIERÍA EN ELECTROMECAÁNICA

**TRABAJO DE TITULACIÓN PREVIO A LA OBTENCIÓN DEL TÍTULO DE INGENIERO
EN ELECTROMECAÁNICA**

**ENTRENAMIENTO VIRTUAL PARA LA OPERACIÓN Y MANTENIMIENTO EN
LÍNEAS ENERGIZADAS**

Autoras:

Moreno Iza, Erika Fernanda
Pacheco Riera, Evelyn Elizabeth

Dr. Andaluz Ortiz, Víctor Hugo. PhD, *Director*
Ing. Mullo Quevedo, Álvaro Santiago, *Codirector*



Future of Information and Communication Conference

FICC 2020

5-6 March, San Francisco



Q3

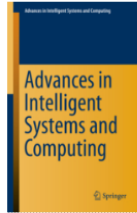

Advances in Intelligent Systems and Computing

Series Ed.: Kacprzyk, Janusz
Originally published with the title : Advances in Intelligent and Soft Computing
ISSN: 2194-5357

[Read Online](#)

Multi-user Expert System for Operation and Maintenance in Energized Lines

Erika F. Moreno, Evelyn E. Pacheco, Víctor H. Andaluz and Álvaro S. Mollo.

Universidad de las Fuerzas Armadas ESPE, Sangolquí - Ecuador
(efmoreno1, eepacheco1, vhandaluz1, asmollo}@espe.edu.ec

Abstract. The article presents the development of a multi-user application in virtual reality for the training and theoretical-practical training of electrical maintenance personnel in the operation of energized lines. The environment has a safety explanatory room in which users will know each of the rules and protocols applied to perform maintenance maneuvers and operation of energized lines, a realistic work area of the electrical power system that starts from hydroelectric generation and passes through transmission lines, subtransmission to reach substations that raise or reduce the voltage for subsequent distribution. The environment has been created using photogrammetry techniques, WorldComposer, CAD design tools, Unity 3D, DigSilent Power Factory and Matlab to provide realism of electrical system behavior, emulating failures and critical conditions caused by external and internal emergency events. Experimental tests show the efficiency of the system generated by human-machine interaction in which operators interact between themselves and the ambience, facilitates immersion in an environment that offers to contribute to the development of their risk-free collaborative skills and abilities.

Keywords: Virtual Reality, Maintenance on Energized Lines, Electrical Power System, Photogrammetry, Unity 3D.



ESPE
UNIVERSIDAD DE LAS FUERZAS ARMADAS
INNOVACIÓN PARA LA EXCELENCIA

ICETC 2019

Amsterdam, Netherlands
October 28-31, 2019



Scopus

The largest abstract and citation database of peer-reviewed
literature from more than 5,000 publishers

DOI: <https://doi.org/10.1145/3369255.3369297>

**Multi-user Virtual Training Assistant for Maintenance on
Energized Medium-Voltage Lines**

Erika F. Moreno, Evelyn E. Pacheco, Victor H. Andaluz and Alvaro S. Mullo
Universidad de las Fuerzas Armadas ESPE, Sangolquí-Ecuador
{efmoreno1, eepacheco1, vhandaluz1, asmullo}@espe.edu.ec

ABSTRACT

The article proposes the implementation of a virtual multi-user tool applied in the field of Electromechanical engineering with the aim of strengthening the training and theoretical-practical training of electrical maintenance personnel of energized lines. The system consists of the implementation of a training area in which safety regulations and protocols applied to perform medium voltage maneuvers are known, in which you can take guided trainings, specific practices of maintenance of energized lines and evaluations of the collaborative maneuvers, which allows for greater immersion and interaction during the teaching-learning process, optimizing training time, resources and infrastructure to guarantee the safety of the operator and his work group. The system allows the selection of the training room, as well as the area in which the maintenance maneuvers will be carried out. At the end of the article we present the results of a usability test of the proposed tool, applied to teachers and students, in order to feedback the application.

In which educational institutions will benefit from better accessibility to technologies, which will allow teaching in virtual environments, visualizing physical classrooms, machines, industrial plants, or even medical scenarios [5] [6]. Several virtual reality applications facilitate training processes in safe environments, among which several research projects are mentioned, such as: *i)* Unity3D virtual animation of robots with coupled and uncoupled mechanism [7]; *ii)* Virtual reality applied to industrial processes [8]; *iii)* Virtual environments for motor fine skills rehabilitation with force feedback [9]; *iv)* Using virtual reality to support the physical security of nuclear facilities [10]; *v)* Desktop (VR) environment for power line workers, the training system aims to reinforce classroom training and bridge theoretical knowledge and field work training [11]; *vi)* Training in virtual environments for a hybrid plant oriented to the simulation of faults and manoeuvres for the training of professionals in Electrical Systems



ESPE
UNIVERSIDAD DE LAS FUERZAS ARMADAS
INNOVACIÓN PARA LA EXCELENCIA

Agenda

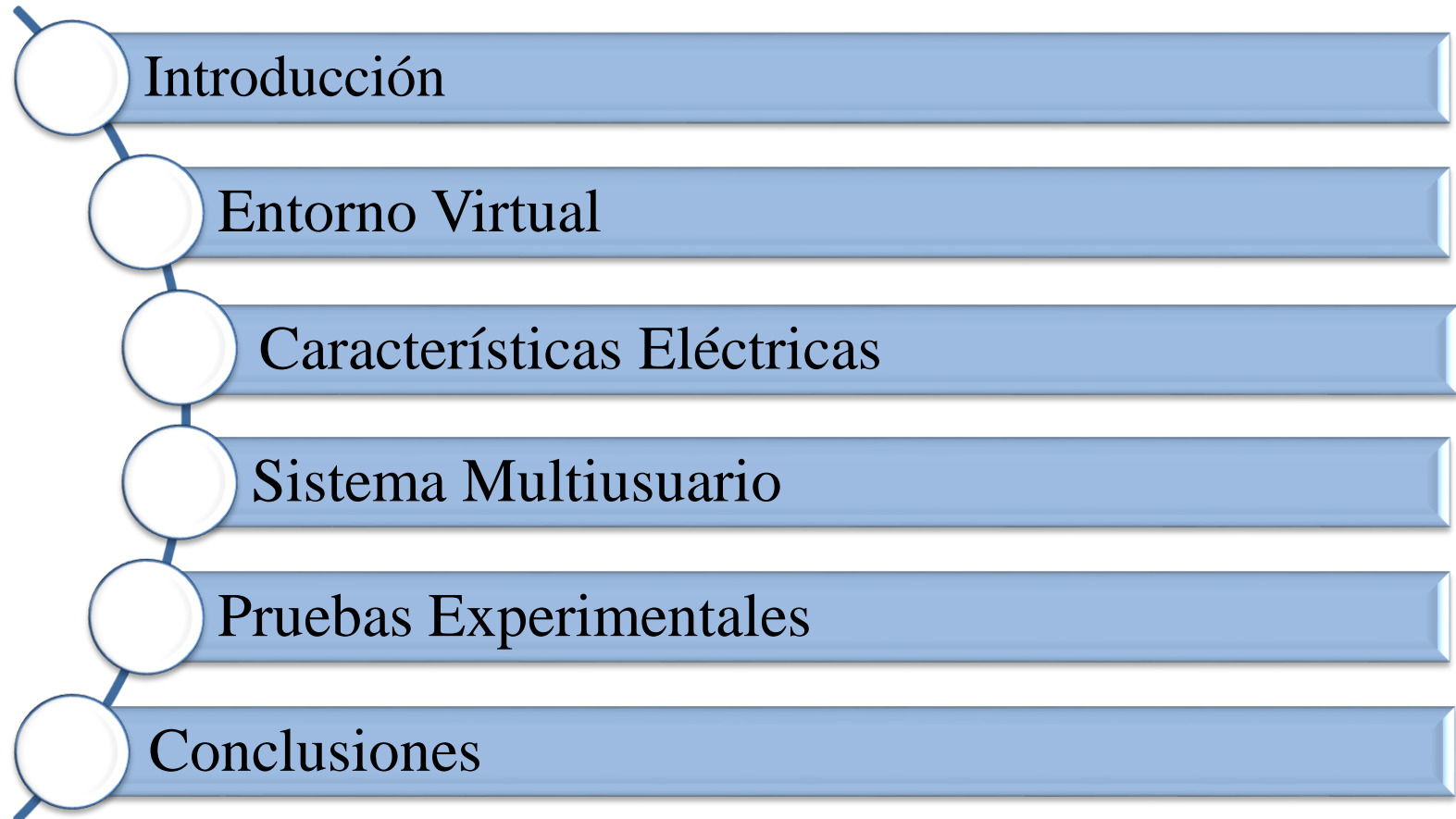

Agenda

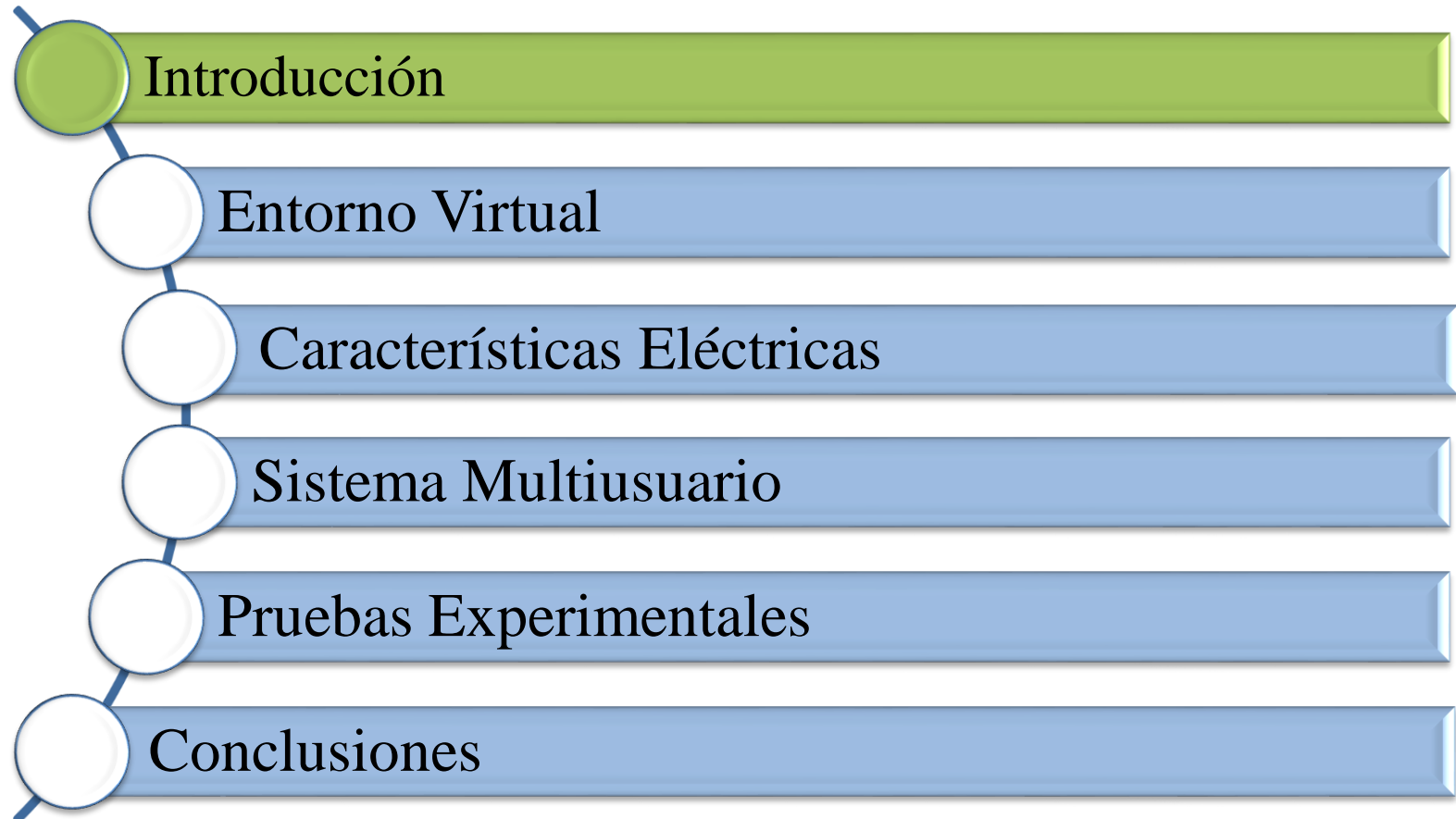

Introducción



Regula/Controla



Coordina S.N.I



Calidad de servicio



Evitar pérdidas



ESPE
UNIVERSIDAD DE LAS FUERZAS ARMADAS
INNOVACIÓN PARA LA EXCELENCIA

Planteamiento del Problema



Costo excesivo de equipos

Falta de áreas de entrenamiento



Realidad Virtual

Inmersión sensorial en un nuevo mundo, **basado en entornos reales** o no, que ha sido generado de forma artificial, en la que se puede percibir los **dispositivos de R.V.** El objetivo de esta tecnología es crear un mundo ficticio para formar parte e incluso ser el protagonista.

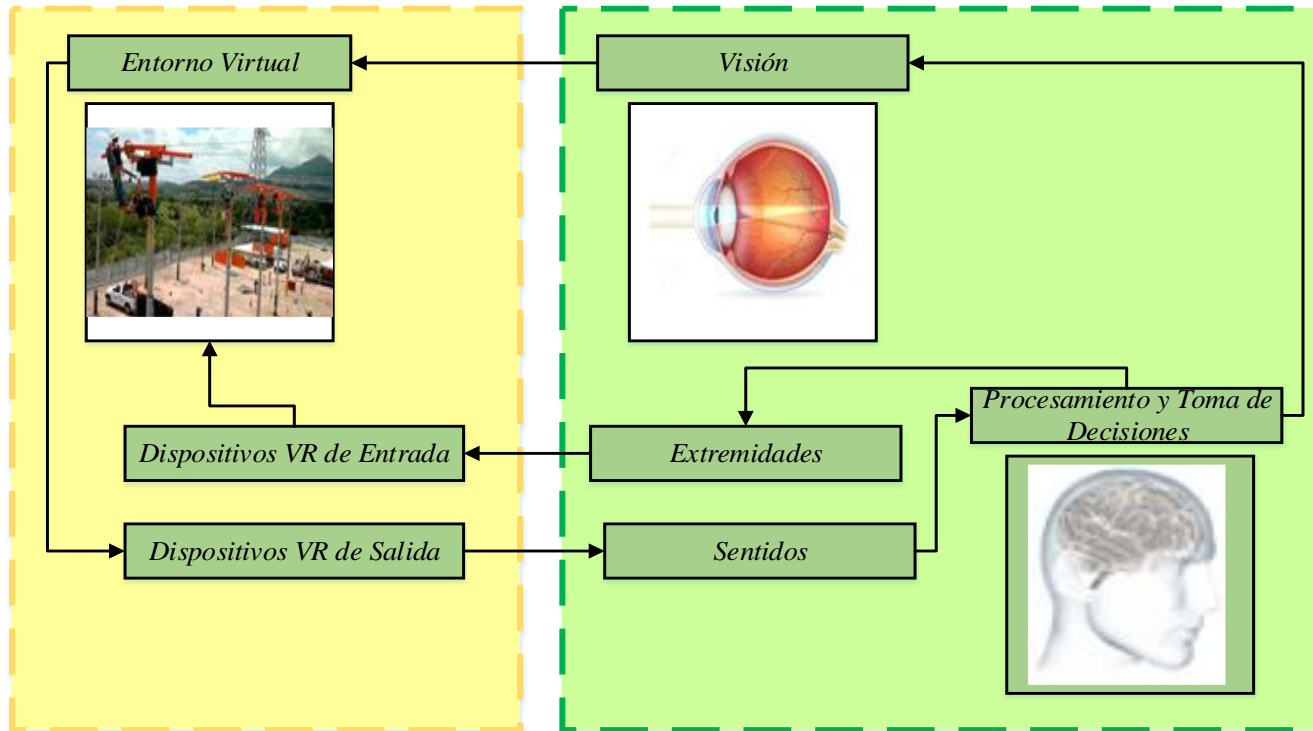

Objetivo General

- Desarrollar un **sistema experto multi-usuario** a través de entornos de realidad virtual para la operación y **mantenimiento en líneas energizadas**, a fin de mejorar las destrezas, habilidades y **trabajo colaborativo** entre el personal de mantenimiento.



Objetivos Específicos

- Revisar y documentar los conceptos teóricos de las **características eléctricas** generadas en las **líneas de subtransmisión y distribución**, normativas de seguridad, aplicaciones colaborativas para la operación y mantenimiento en líneas energizadas y realidad virtual; mediante la investigación bibliográfica para el desarrollo del proyecto.
- **Virtualizar** un entorno real de la línea de subtransmisión y distribución a través de **técnicas de fotogrametría y modelos CAD** para crear las escenas de trabajo.
- Desarrollar una **interfaz virtual 3D** que permita implementar diferentes **protocolos de seguridad**, a fin de ejecutar tareas colaborativas orientadas a la operación y mantenimiento en líneas energizadas.

Objetivos Específicos

- Implementar un **sistema multi-usuario** que permita que varios usuarios, dependiendo de su **nivel jerárquico**, puedan interactuar de forma **simultánea** en un entorno virtual para la ejecución de **tareas de mantenimiento** en líneas energizadas.
- **Evaluar** el funcionamiento de la **aplicación virtual** mediante la evaluación Heurística a fin de determinar el desempeño del personal de mantenimiento con el entorno.

Agenda

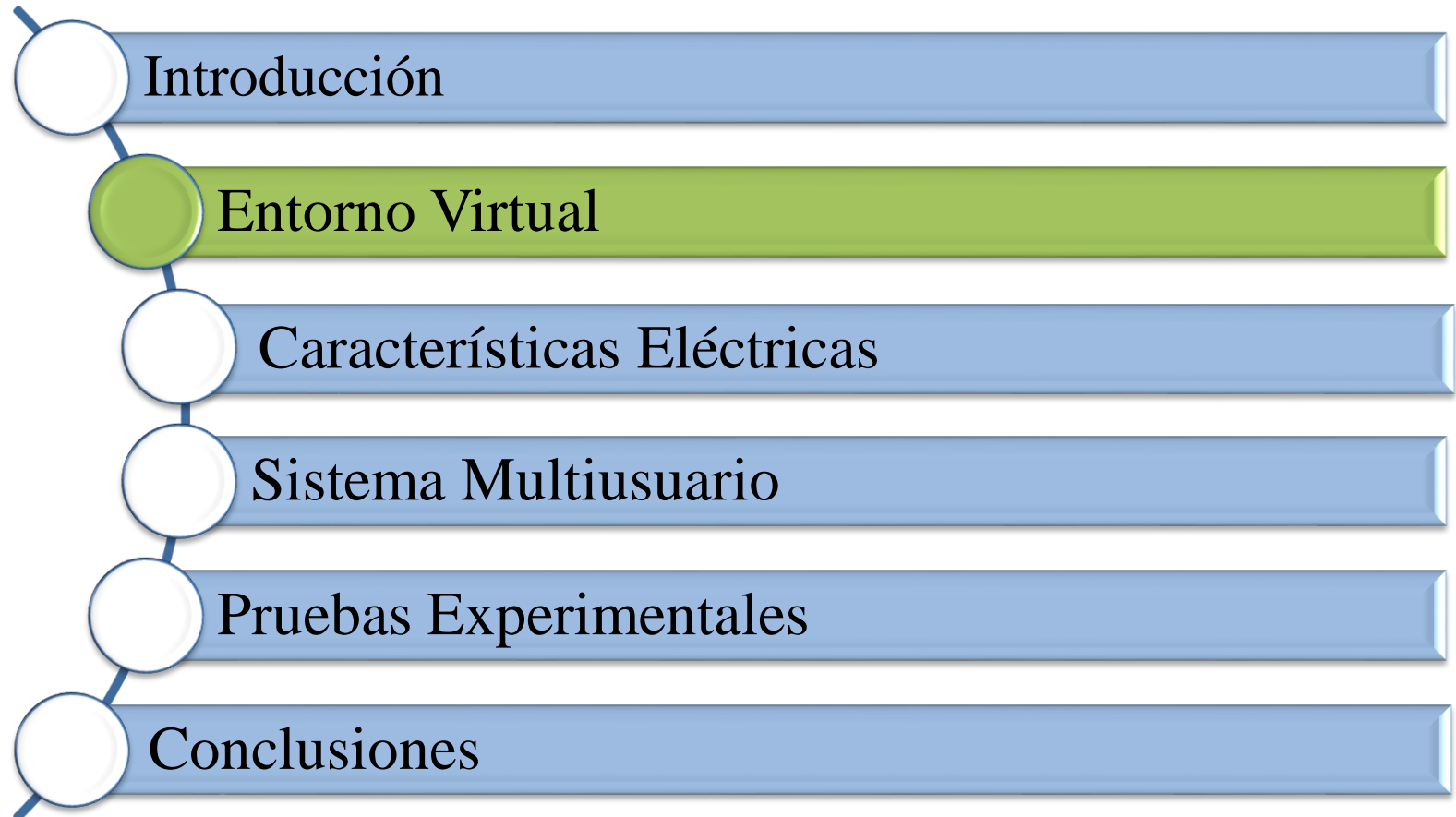

Estructura del sistema

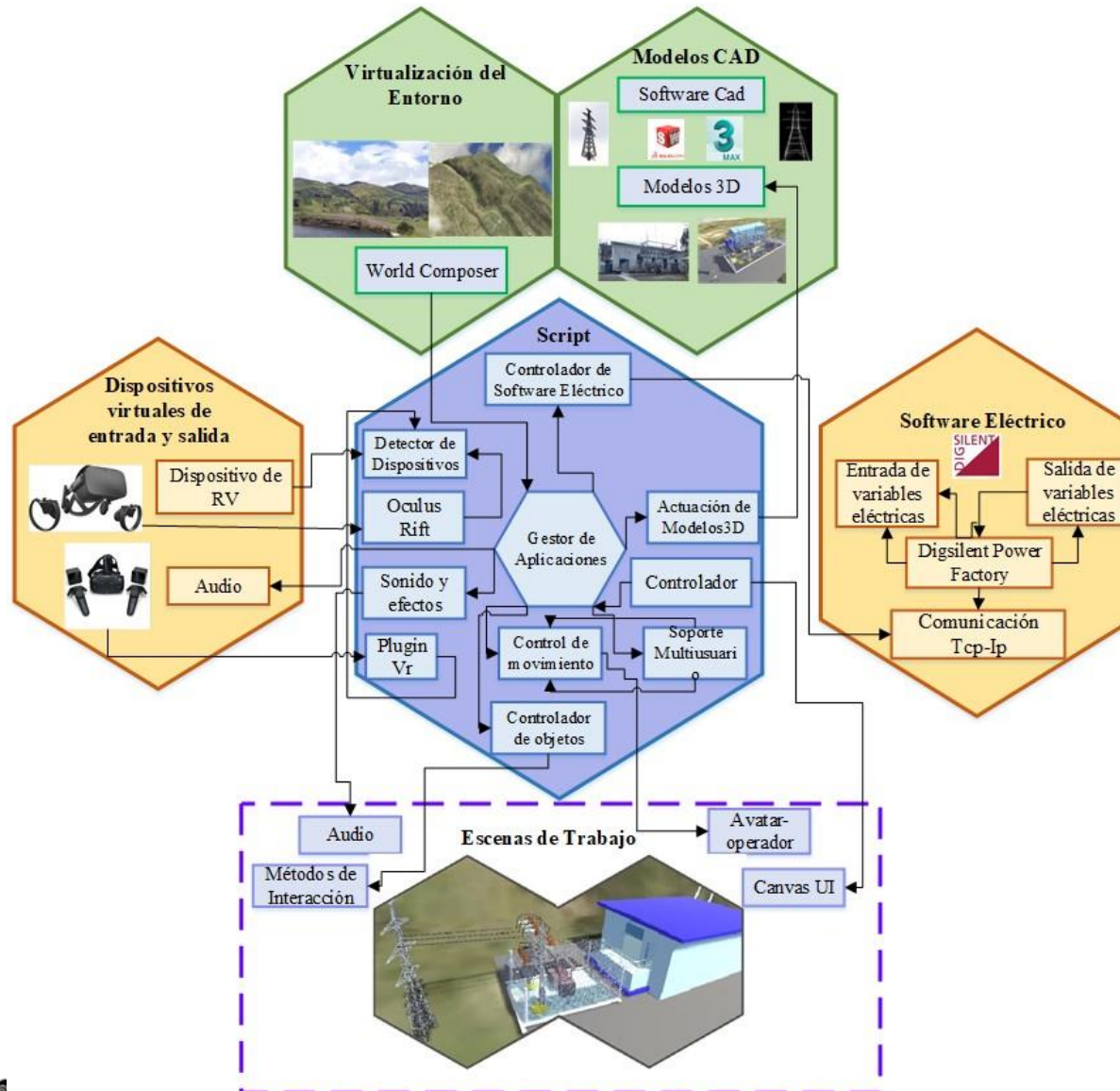

Digitalización



Digitalización

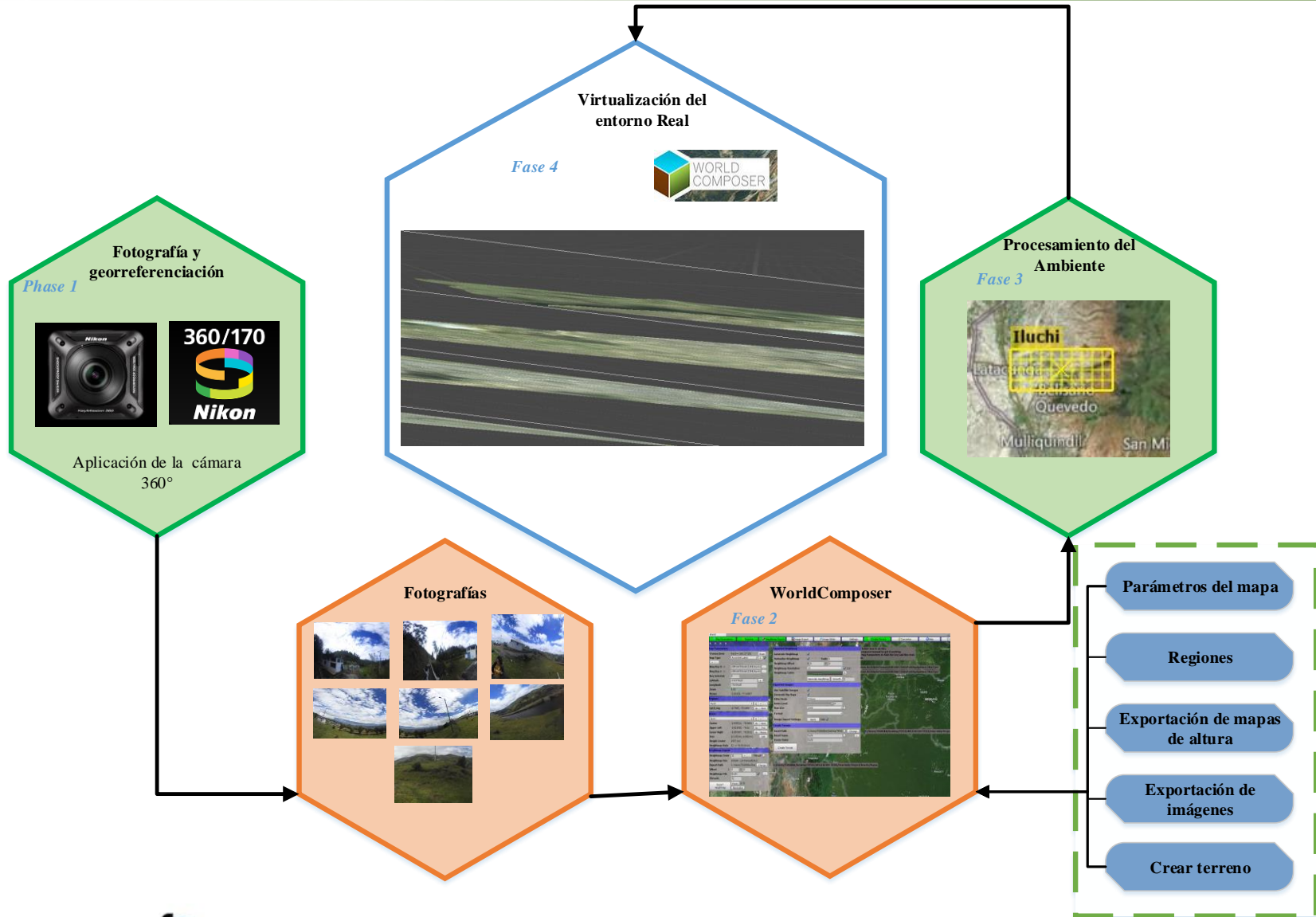

Entorno Unity 3D

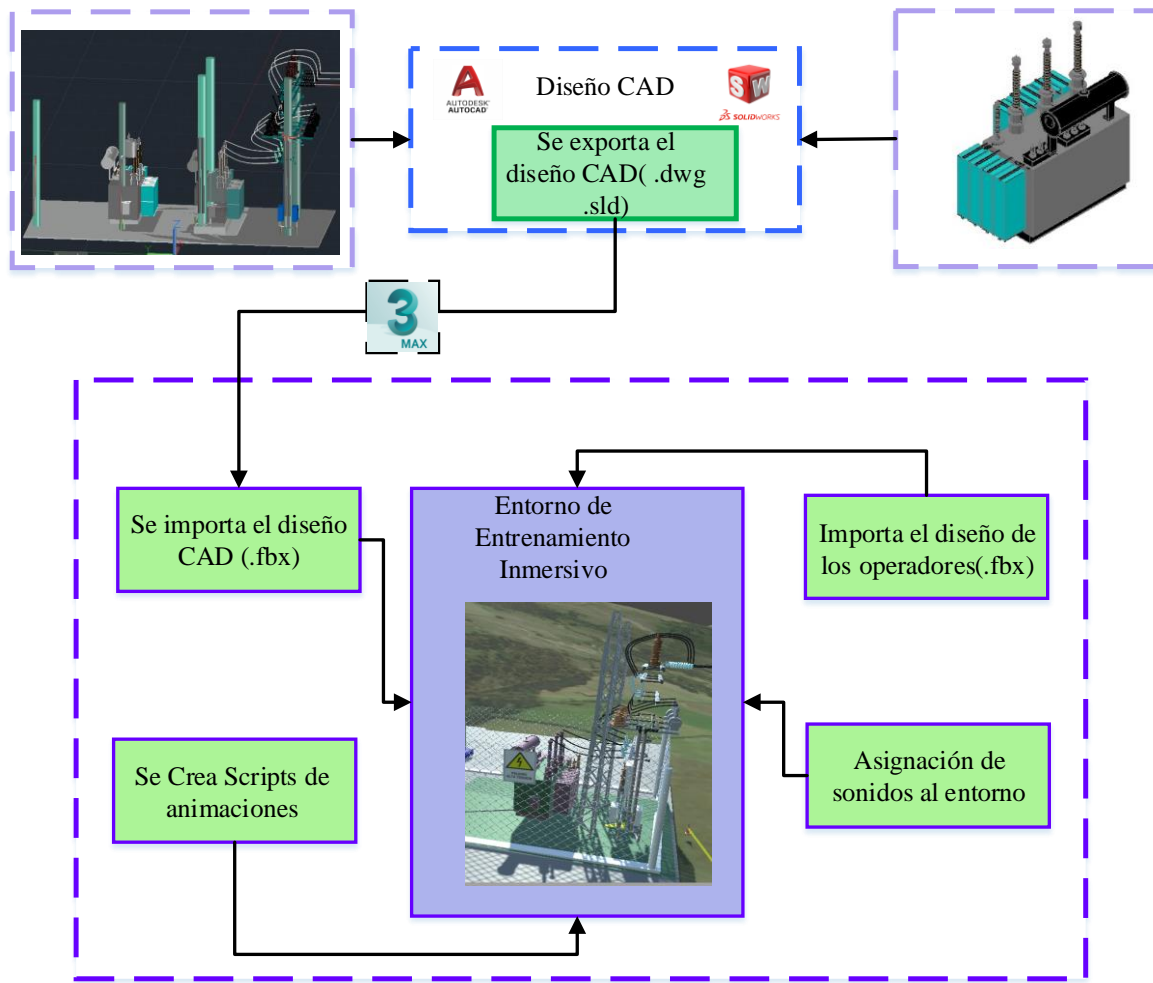

Entorno 3D

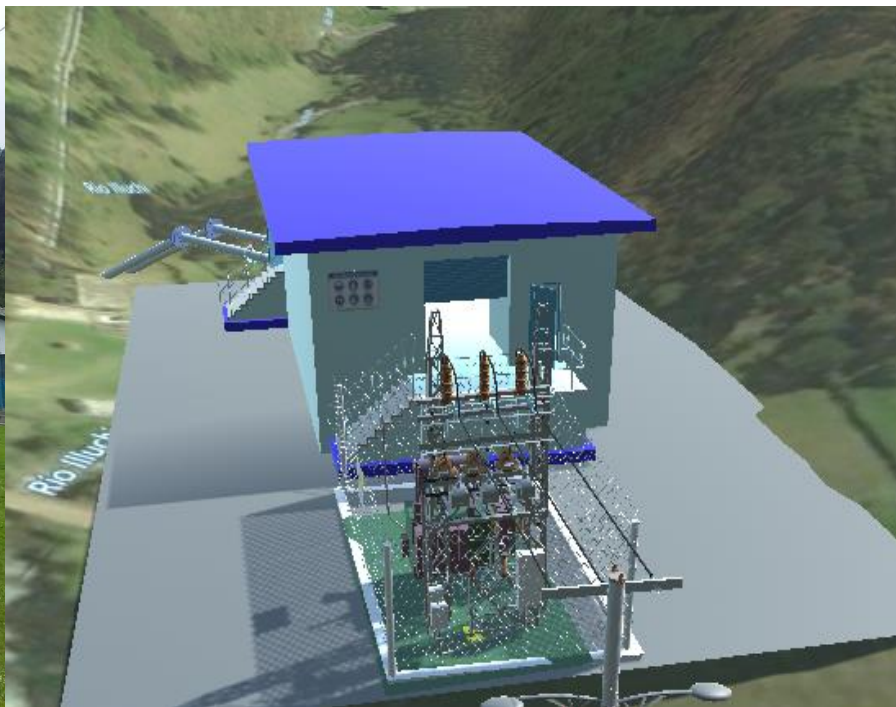

Entorno 3D

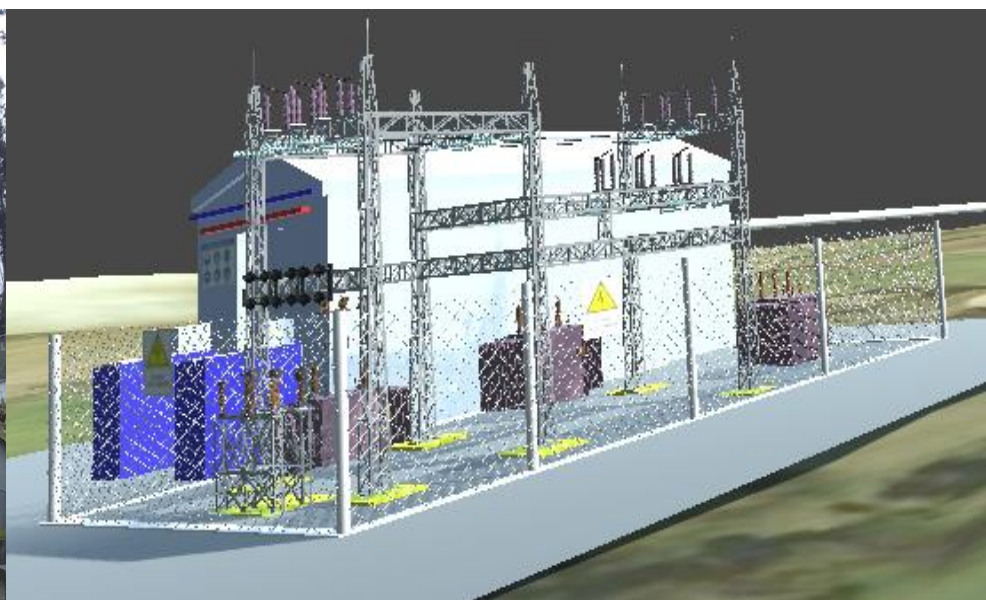

Entorno 3D

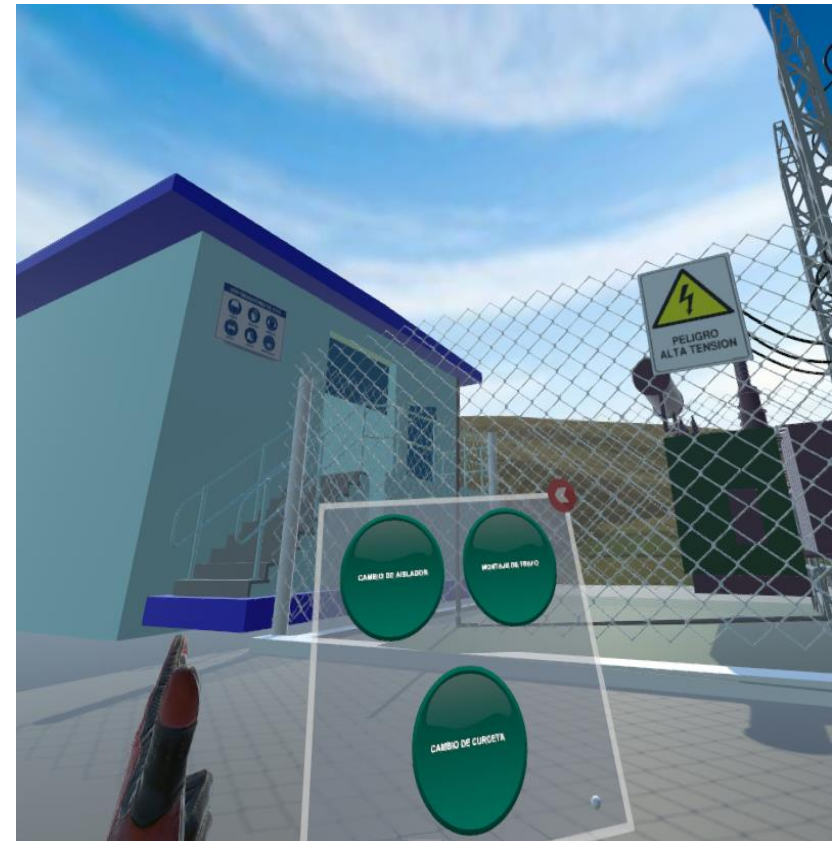
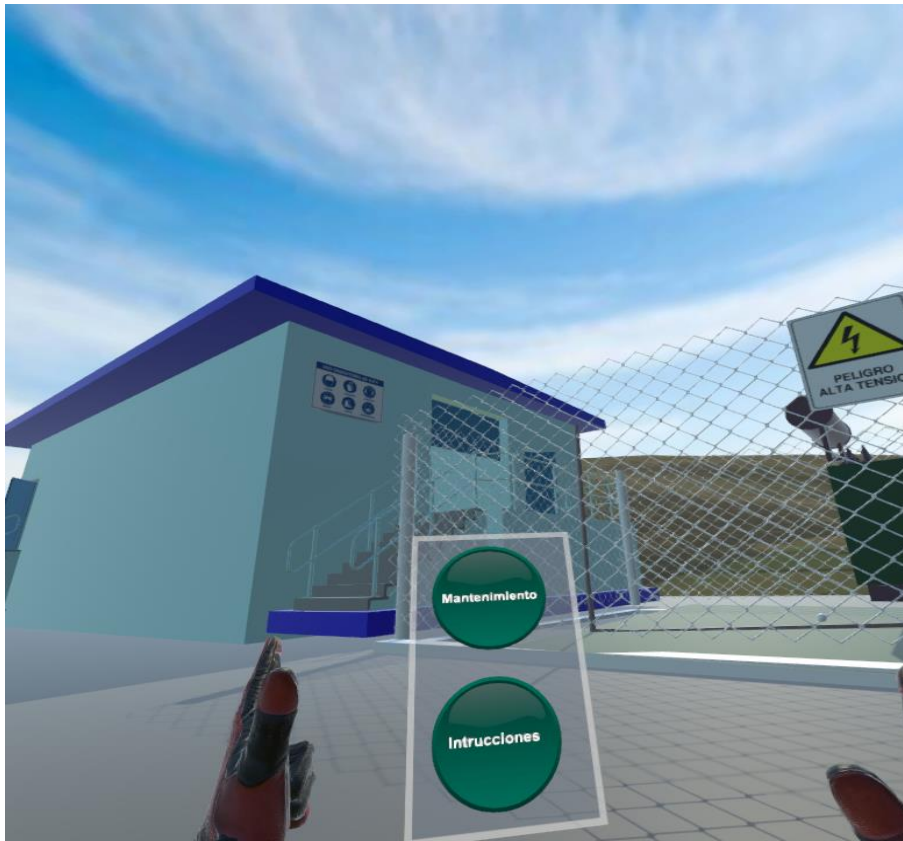

Entorno 3D

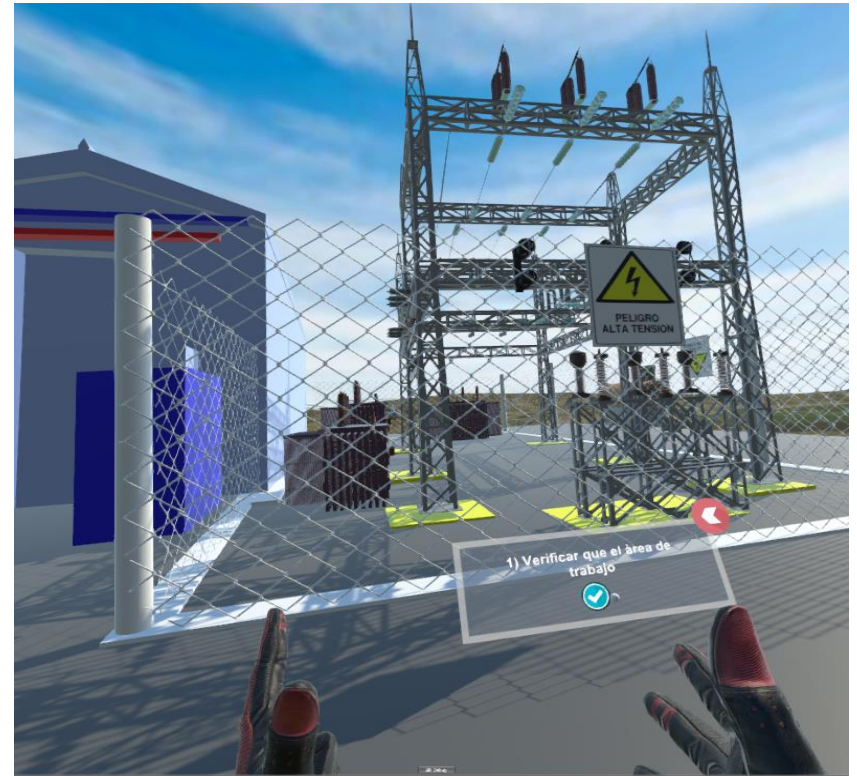
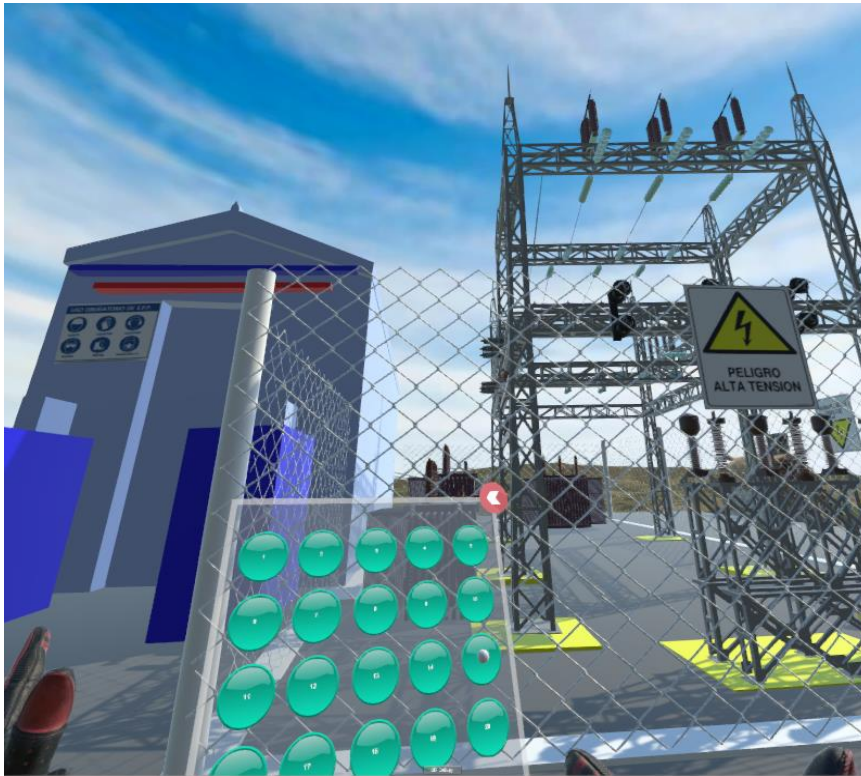

Jerarquías



Agenda

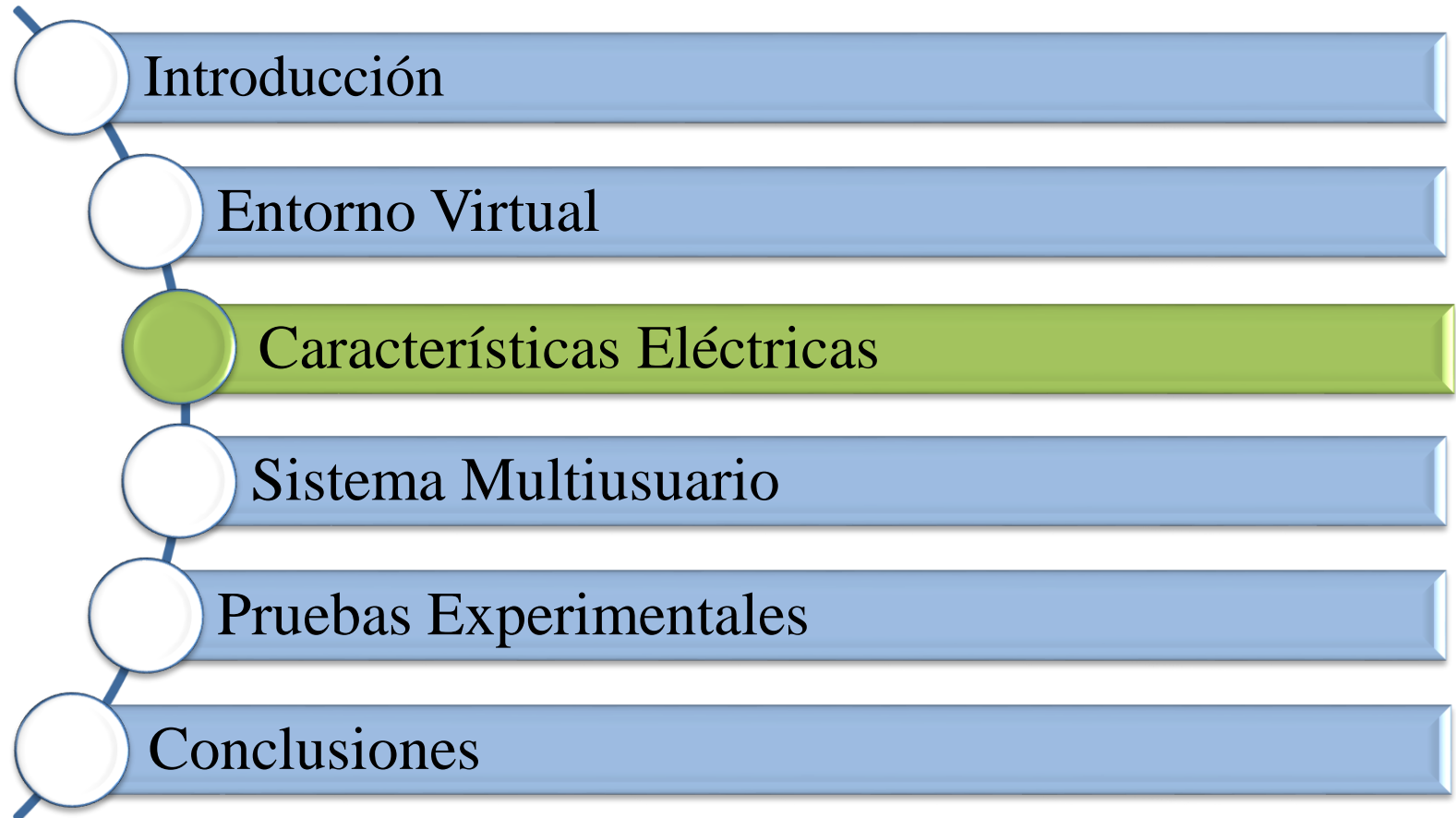

Comunicación TCP-IP

Matlab-Unity 3D

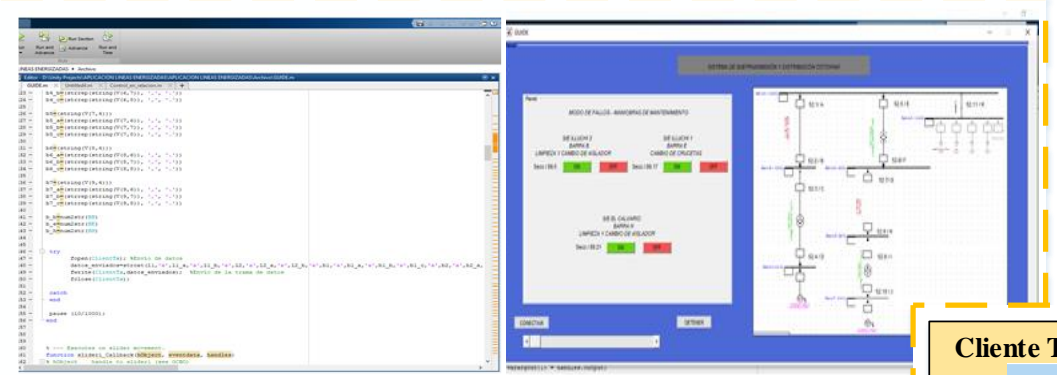

The image shows a MATLAB script on the left and a 3D control interface on the right. The script contains code for defining variables and functions. The 3D interface, titled 'SERVIDOR DE SUPERVISION Y CONTROL DE ESTADO', features a central network diagram with nodes labeled 'SE 1A' through 'SE 10'. Below the diagram are control panels for 'SE ALUMBRADO' and 'SE B. CALOR', each with 'IMPEDIR Y CAMBIO DE ESTADO' and 'SEAL' buttons. A yellow callout box with the MATLAB logo and the text 'Cliente TCP/IP' is positioned to the right of the 3D interface.



The image displays a Unity 3D environment on the right, showing a truck and a landscape with a red arrow pointing towards a building. On the left, a C# script is shown with a red box highlighting the 'Start' method. A yellow callout box with the Unity logo and the text 'Servidor TCP/IP' is positioned to the left of the 3D environment.

Adquisición de datos Digsilent-Matlab

DIG SILENT
Diagrama Software Digsilent



 Creación DPL



 Archivo .txt

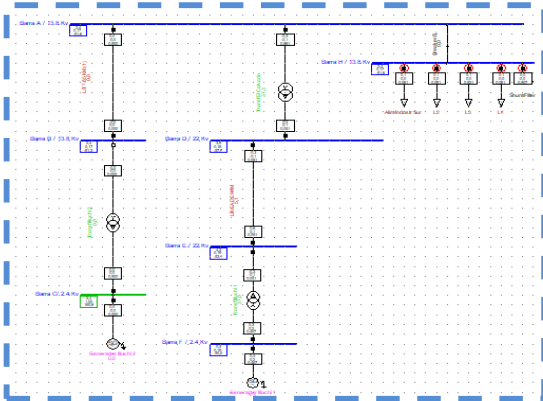

```
DPL Command - Analisis 2.ComDpl
Basic Options
Advanced Options
Script
Description
Version

Program text
set: FuerzaServicio, err;
set: S_Lineas;
set: S_Voltajes;
object: Q_Lineas;
object: Q_Voltajes;
S_Lineas=Lineas.AllElm();
Q_Lineas=S_Lineas.First();

S_Voltajes=Voltajes.AllElm();
Q_Voltajes=S_Voltajes.First();

EchoOn();
ABRIR EL ARCHIVO TXT
fopen('C:\Users\EL\Desktop\Archivo\archivo.txt','w',0);

Ldr.Execute();
err.Ldr.Execute();
printf('%d',err);
if (err==0)
printf('converge el flujo');
else
printf('no converge');
}
OBTENER DATOS
Lineas.Execute();
```

*archivo: Bloc de notas

Archivo	Edición	Formato	Ver	Ayuda
L/T DE 9 KM	0,05		0,01	
L/T DE 7.65 KM	0,05		0,00	
Barra A / 13.8 Kv			13,80	
Barra F / 2.4 Kv			2,40	
Barra D / 22 Kv			22,00	
Barra E / 22 Kv			22,00	
Barra B / 13.8 Kv			13,80	
Barra C / 2.4 Kv			2,40	
Barra G / 13.8 Kv			13,80	



```
Editor - C:\Users\EL\Desktop\Archivo\Untitled4.m
Untitled4.m x GUIDEm x +
1 - tic, clear all;
2 - [a,b,c,d,e,f,g,h]=textread('archivo.txt','%s %s %s %s %s %s');
3 - VB[a,b,c,d,e,f,g,h]
4 - %LINEAS
5 - l1=strcmp2num(string(V(1,3)))
6 - l1_a=strcmp2num(strep(string(V(1,5))), '%f', '%f')
7 - l1_b=strcmp2num(strep(string(V(1,6))), '%f', '%f')
8 - l2=strcmp2num(string(V(2,3)))
9 - l2_a=strcmp2num(strep(string(V(2,5))), '%f', '%f')
10 - l2_b=strcmp2num(strep(string(V(2,6))), '%f', '%f')
11 - %BARRAS
12 - b1=strcmp2num(string(V(3,4)))
13 - b1_a=strcmp2num(strep(string(V(3,6))), '%f', '%f')
14 - b1_b=strcmp2num(strep(string(V(3,7))), '%f', '%f')
15 - b1_c=strcmp2num(strep(string(V(3,8))), '%f', '%f')
16 -
17 - b2=strcmp2num(string(V(4,4)))
18 - b2_a=strcmp2num(strep(string(V(4,6))), '%f', '%f')
19 - b2_b=strcmp2num(strep(string(V(4,7))), '%f', '%f')
20 - b2_c=strcmp2num(strep(string(V(4,8))), '%f', '%f')
21 -
22 - b3=strcmp2num(string(V(5,4)))
23 - b3_a=strcmp2num(strep(string(V(5,6))), '%f', '%f')
24 - b3_b=strcmp2num(strep(string(V(5,7))), '%f', '%f')
25 - b3_c=strcmp2num(strep(string(V(5,8))), '%f', '%f')
```

 Script Matlab

Diagrama Eléctrico

Line - Iluchi 2L/T DE 7.65 KM.Elmline

Basic Data

Name: **Y/T DE 7.65 KM**

Type: **Equipment Type Library/LINEA DE 7.65 KM**

Terminal I: **Iluchi 2-Barras A / 13.8 Kv/C.b._1** Barra A / 13.8 Kv

Terminal J: **Iluchi 2-Barras B / 13.8 Kv/C.b._2** Barra B / 13.8 Kv

Zone: Terminal

Area: Terminal

Out of Service

RMS Simulation

EMT Simulation

Harmonics Power Quality

Optimal Power Flow

Reliability

Generation Adequacy

Tie Open Point Opt.

Cable Stang

Description

Parameters

Thermal Rating: **1**

Length of Line: **7.650001** km

Densifying Factor: **1**

Laying: **Ground**

Type of Line: **Cable**

Lumped Parameter (PI)

Distributed Parameter

Sections/Line Loads

Resulting Values

Rated Current (act.): **0.385 kA**

Pos. Seq. Impedance, Z1: **3.924119 Ohm**

Pos. Seq. Impedance, Angle: **72.23618 deg**

Pos. Seq. Resistance, R1: **1.197225 Ohm**

Pos. Seq. Reactance, X1: **3.1737025 Ohm**

Zero Seq. Resistance, R0: **1.197225 Ohm**

Zero Seq. Reactance, X0: **3.1737025 Ohm**

Earth-Fault Current, Ice: **0.6165242 A**

Earth Factor, Magnitude: **0.**

Earth Factor, Angle: **0. deg**



Diagrama Eléctrico

Line - Iluchi 2L/T/DE 7.65 KM.ElmiLine

Name: **LINEA DE 7.65 KM**

Type: Equipment Type Library/LINEA DE 7.65 KM

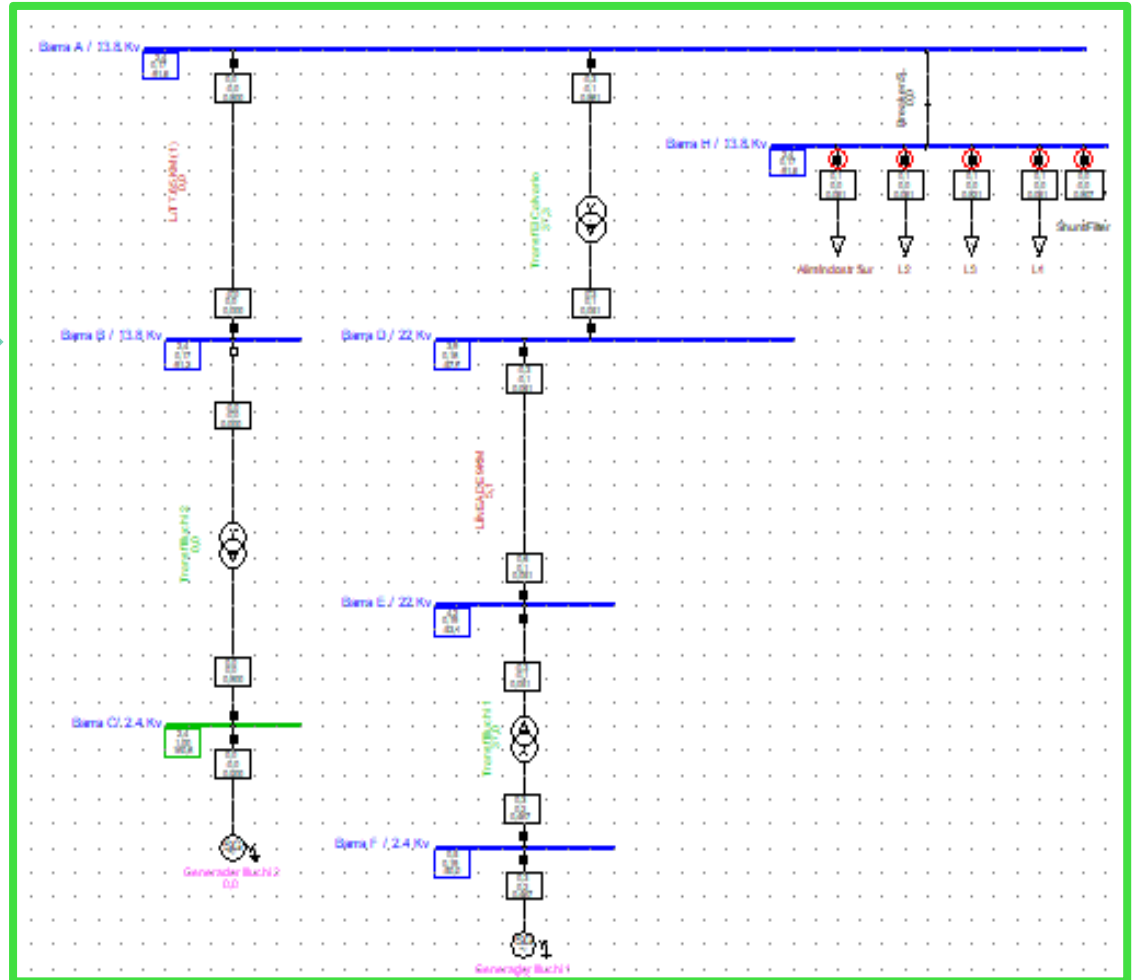
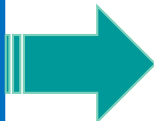
Terminal: Iluchi 2-Barra A / 13.8 Kv/C.6_1 Barra A / 13.8 Kv

Terminal: Iluchi 2-Barra B / 13.8 Kv/C.6_2 Barra B / 13.8 Kv

Zone: Terminal: -

Area: Terminal: -

Out of Service:

RMS-Simulation: Number of parallel Lines: 1

EMT-Simulation: Resulting Values

Parameters:

Thermal Rating: -

Length of Line: 7.650001 km

Reliability: Derating Factor: 1

Generation Adequacy: Tie Open Point Opt. Laying: Ground

Cable Stang

Description

Resulting Values:

Rated Current (act.)	0.385 kA
Pos. Seq. Impedance, Z1	3.924119 Ohm
Pos. Seq. Impedance, Angle	72.23618 deg
Pos. Seq. Resistance, R1	1.197225 Ohm
Pos. Seq. Reactance, X1	3.737025 Ohm
Zero Seq. Resistance, R0	1.197225 Ohm
Zero Seq. Reactance, X0	3.737025 Ohm
Earth Fault Current, Ice	0.6165242 A
Earth Factor, Magnitude	0
Earth Factor, Angle	0 deg

Type of Line: Cable

Line Model: Lumped Parameter (PI) Distributed Parameter

Sections/Line Loads



Diagrama Eléctrico



Agenda

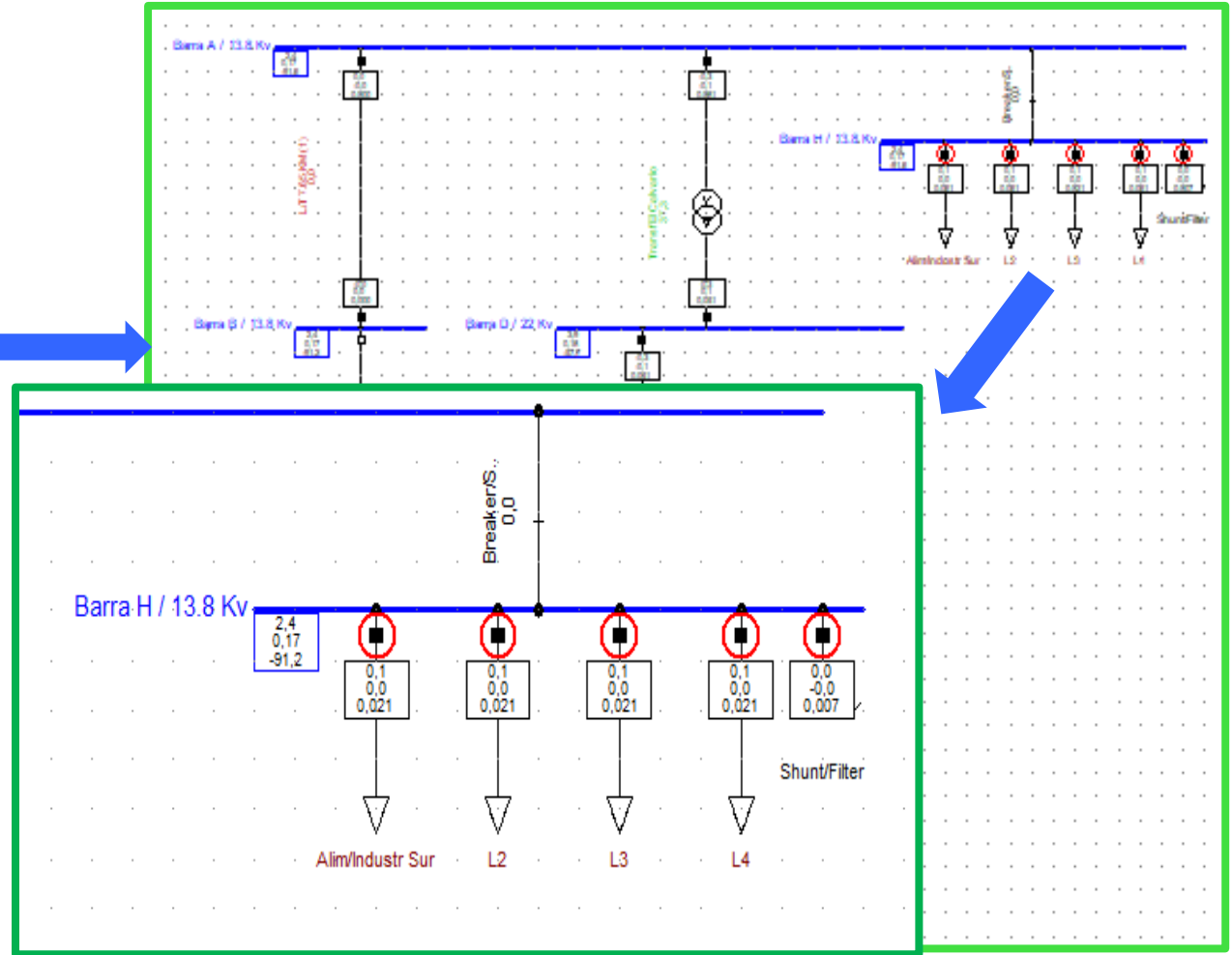
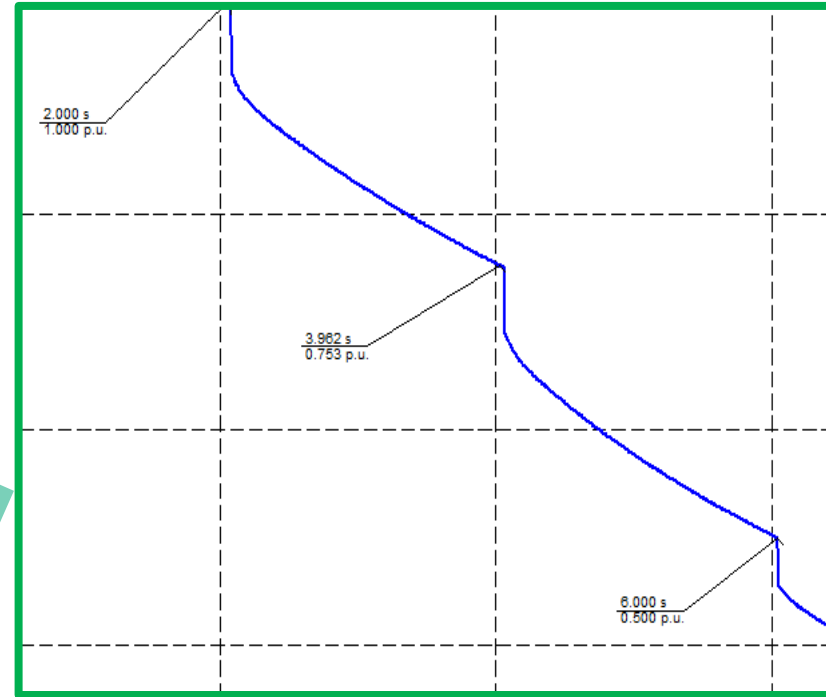
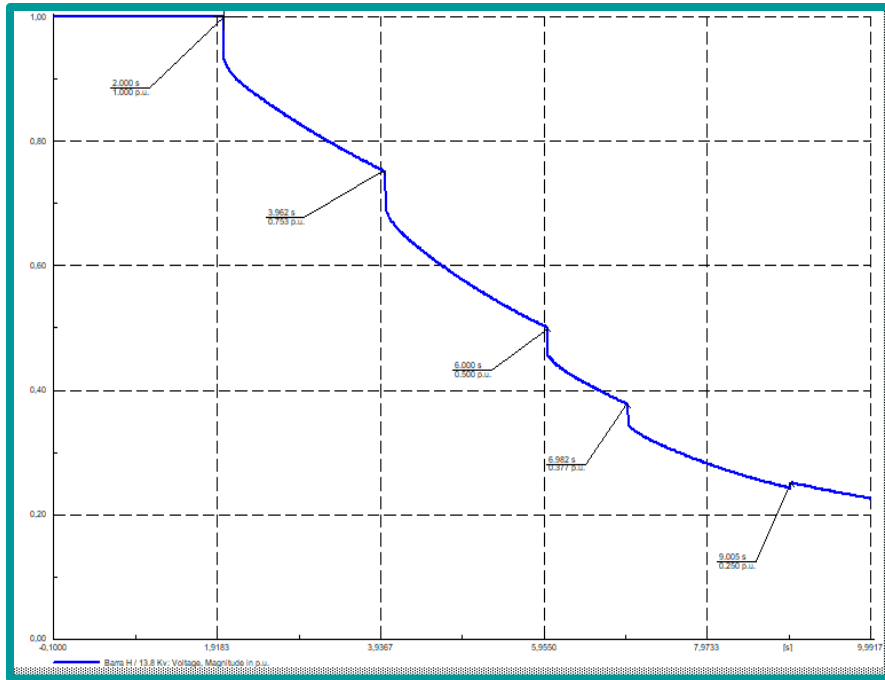
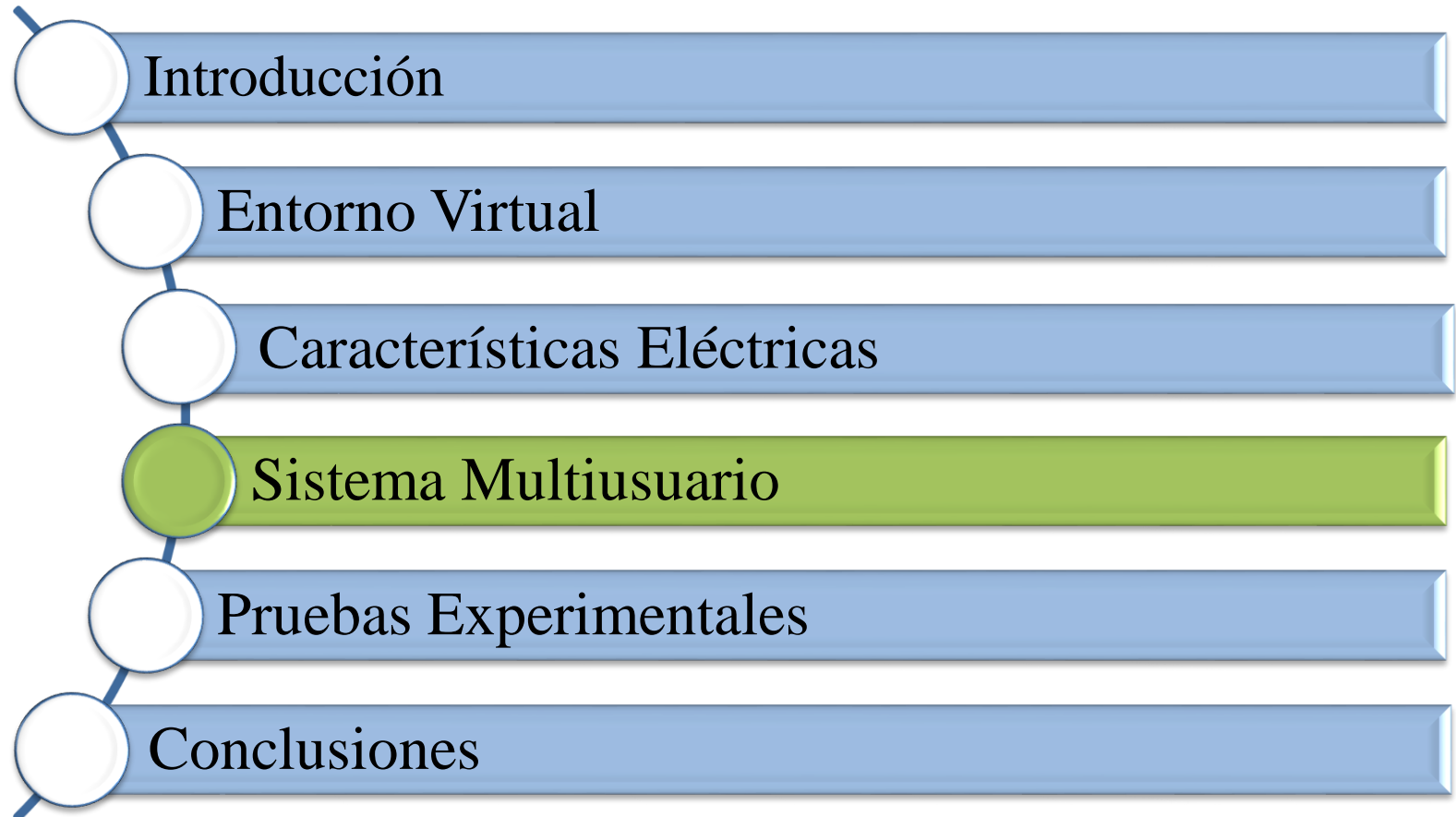

Multi-Usuario

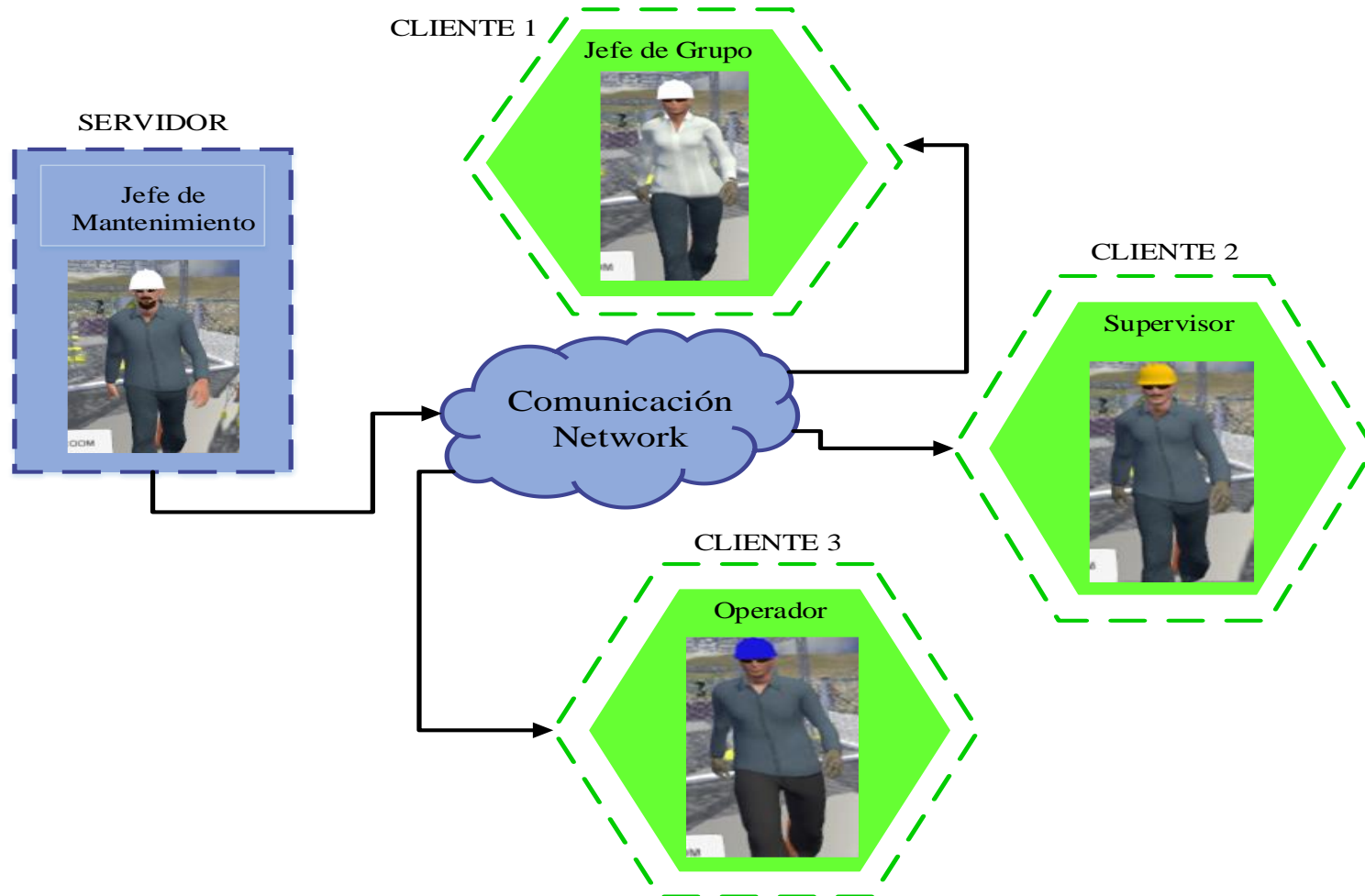

Multi-usuario

UNITY ASSETS

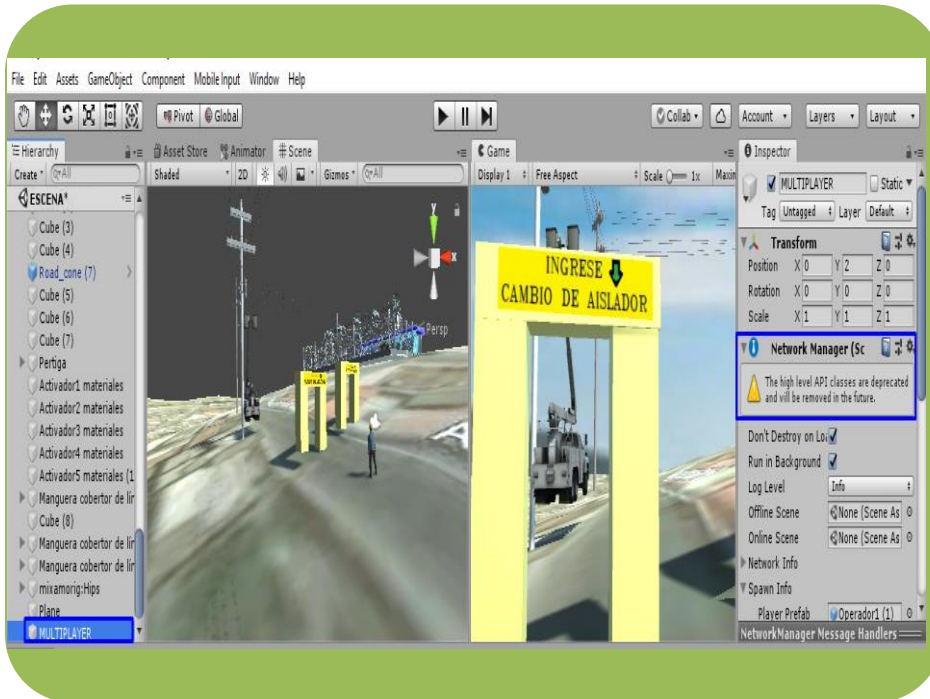

CIFRAR DATOS

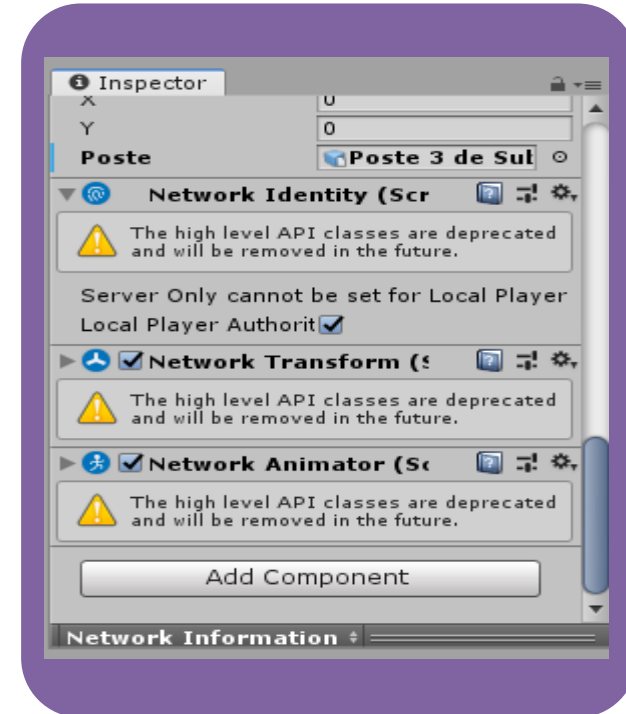

Multi-Usuario

PLATAFORMA

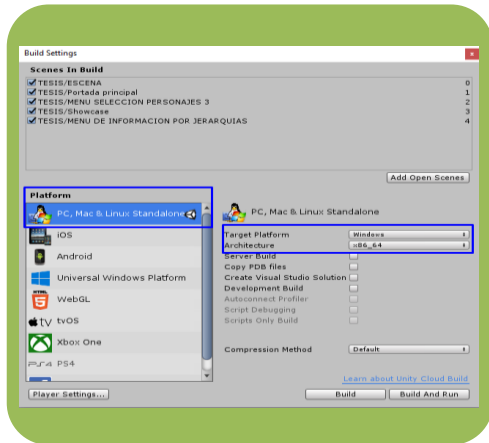

DATA BASE

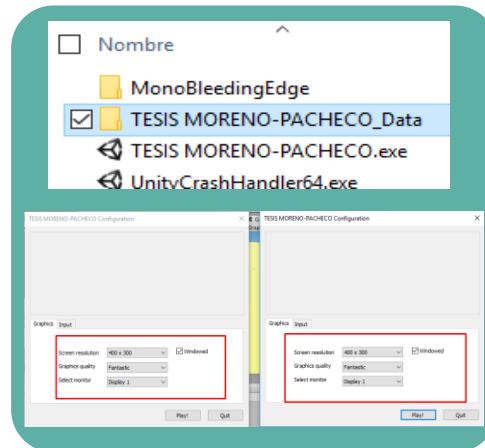

SISTEMA COLABORATIVO MULTI-USUARIO



Agenda

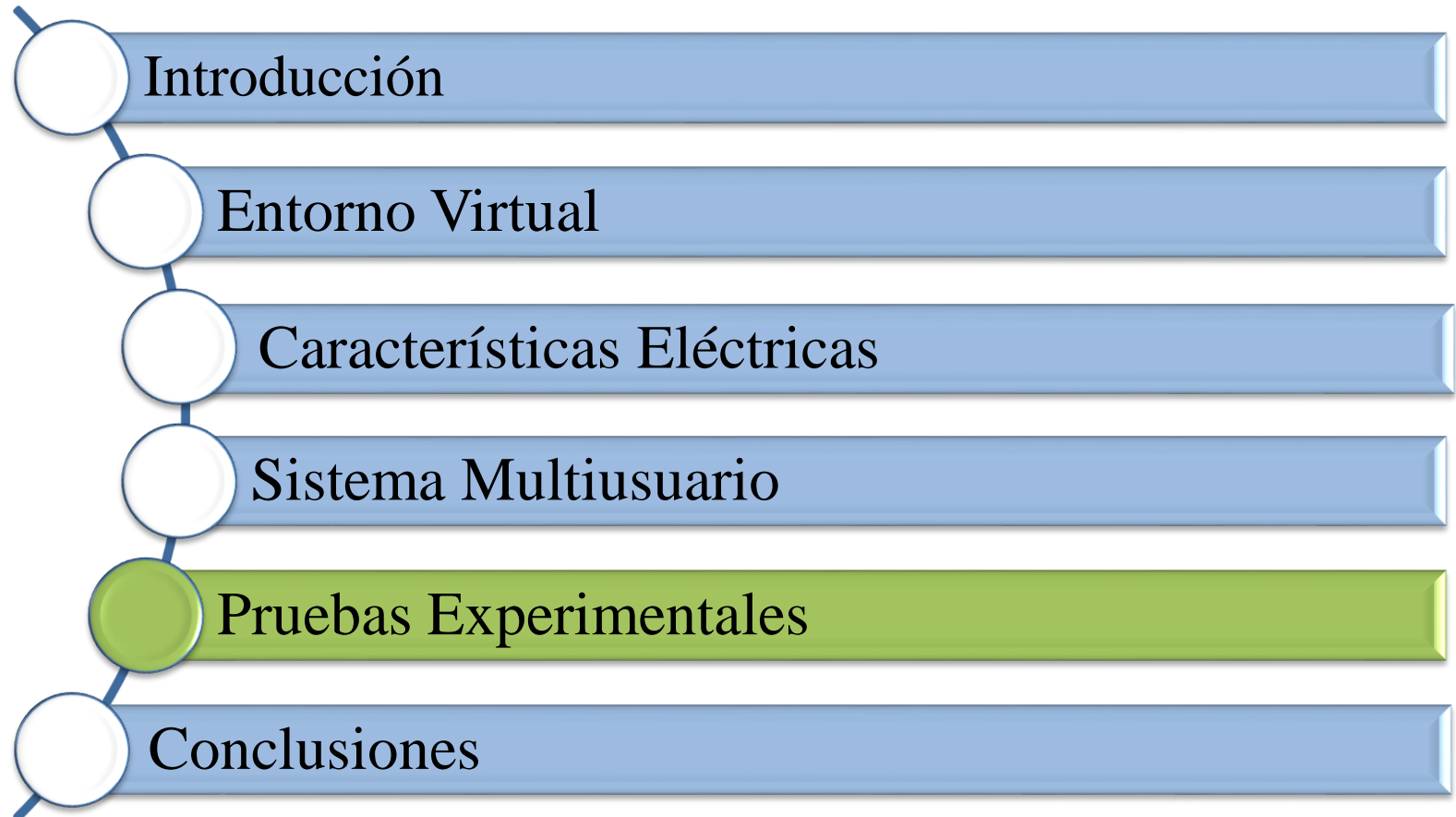

Entorno e Inmersión

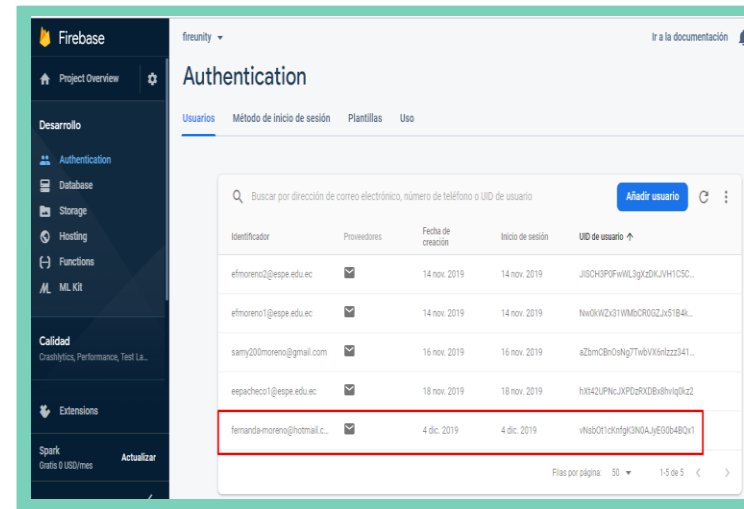

Entorno e Inmersión

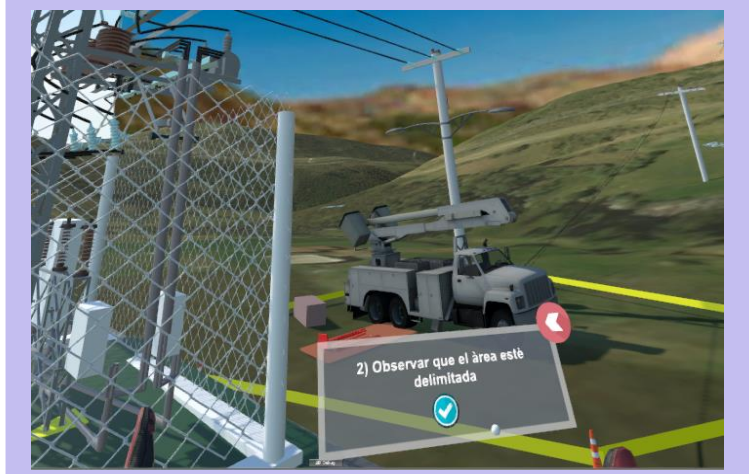
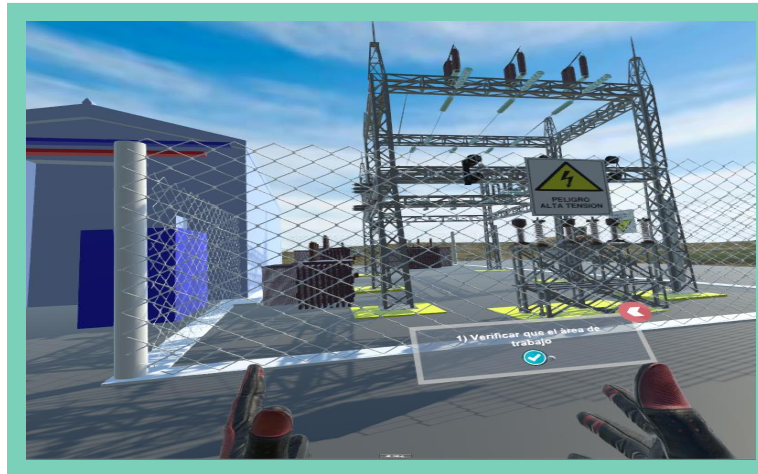
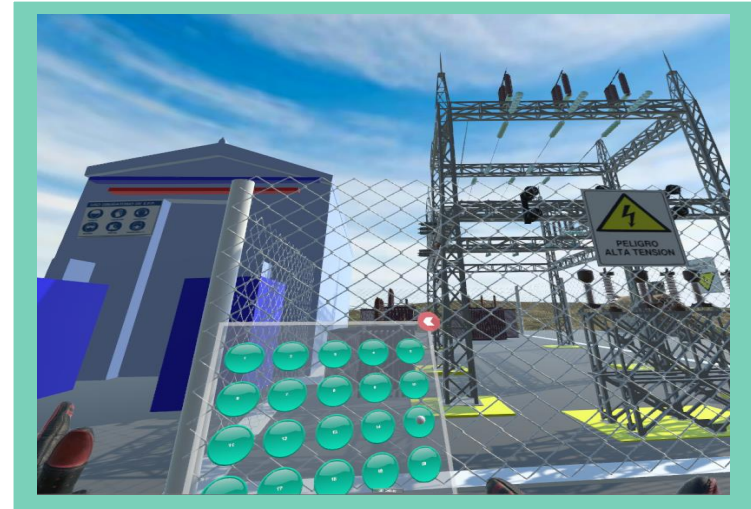
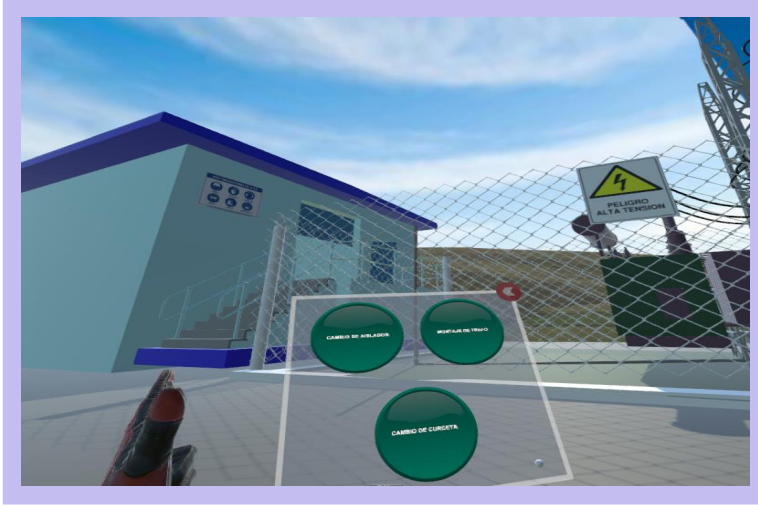

Modo de Fallas en el Sistema



FALLO EN LA BARRA E

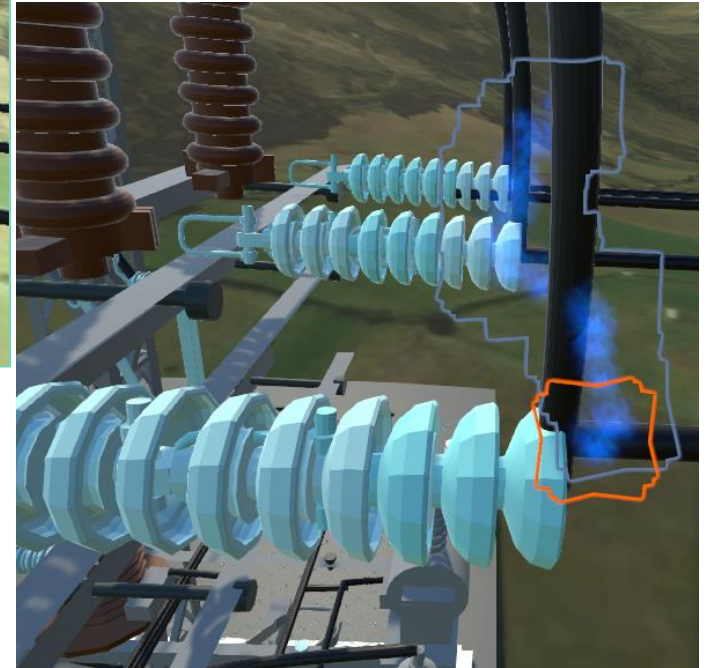

Validación de Resultados

Encuesta de Usabilidad SUS

Nº-	PREGUNTAS
1	¿Ha utilizado los dispositivos de realidad virtual: HTC Y GEAR VR?
2	¿ El asistente de entrenamiento para capacitación en líneas energizadas es fácil de utilizar e intuitiva?
3	¿El entorno de realidad virtual cuenta con todos los elementos de un sistema eléctrico para familiarizarse de mejor manera?
4	¿Necesita de la ayuda externa de un técnico para el uso de la aplicación?
5	¿ Puede realizar con facilidad las operaciones de mantenimiento mostradas por la aplicación?
6	¿La señalética mostrada en el entorno contribuyó al aprendizaje en seguridad?
7	¿El sistema multi-usuario le permitió interactuar de manera colaborativa en las diferentes operaciones de mantenimiento con varios usuarios a la vez?
8	¿La aplicación le ayudó a mejorar sus habilidades cognitivas y colaborativas?
9	¿ Recomendaría el sistema expert de entrenamiento como una herramienta extra de capacitación teórico-práctica que se imparte en el ámbito educativo?
10	¿ El aprendizaje mediante tecnologías de realidad virtual es novedoso para aplicarlo en la educación?

Agenda

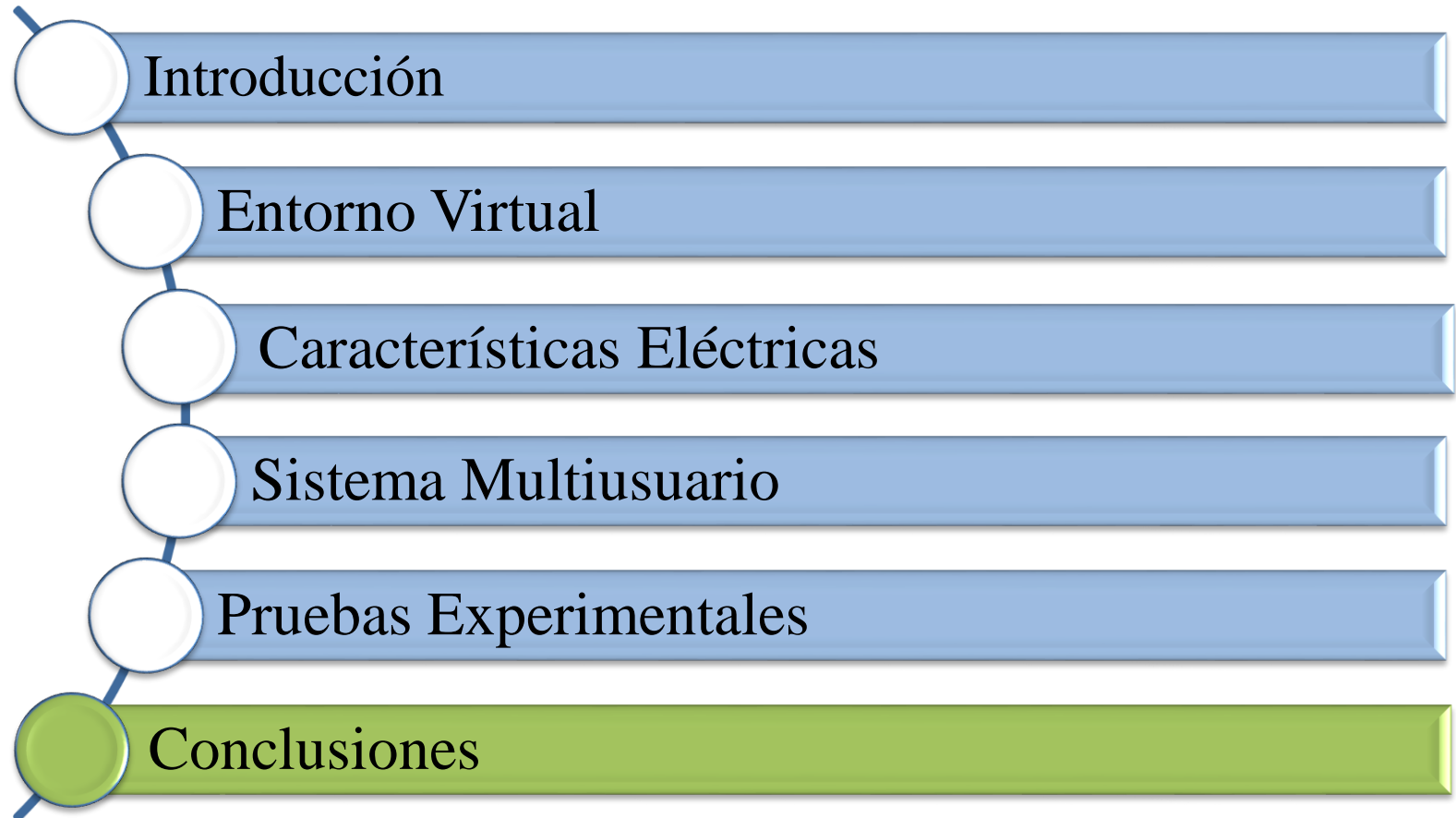

Conclusiones

- El desarrollo de **aplicaciones en realidad virtual** en el **área eléctrica**, ofrecen un seguimiento asistido al usuario dentro del **reconocimiento de procesos y elementos eléctricos** de sub-transmisión y distribución, contribuyendo a la **formación y capacitación** de profesionales, mediante la **inmersión e interacción** al realizar maniobras de operación y mantenimiento en un ambiente **libre de riesgos**, optimizando los recursos económicos, tiempo e infraestructura.

- A través de la **investigación** bibliográfica se documentó las **normas, protocolos** a la vez las características de los elementos eléctricos del sistema de potencia para **aplicarlos** en el **asistente experto** de mantenimiento y operación en líneas energizadas,.

Conclusiones

- Mediante **técnicas de fotogrametría y modelado 3D** se desarrolló la virtualización y creación de escenas del **entorno real de trabajo** del sistema eléctrico de potencia.

- A través de la **interfaz virtual 3D** los operadores acceden al asistente de acuerdo a las **responsabilidades** establecidas a fin de lograr la **inmersión e interacción** en el ambiente de trabajo.

Conclusiones

- La aplicación desarrollada en el motor gráfico Unity 3D proporciona el **realismo de un Sistema Eléctrico de Potencia** que mediante el sistema multi-usuario los operadores interactúan entre sí cuyos resultados experimentales hacen evidente el **desarrollo** de las **capacidades** y **habilidades** en un ambiente **colaborativo**, innovando en una **herramienta extra de capacitación** en los modelos actuales de aprendizaje.



ESPE

UNIVERSIDAD DE LAS FUERZAS ARMADAS
INNOVACIÓN PARA LA EXCELENCIA

DEPARTAMENTO DE ELÉCTRICA Y ELECTRÓNICA

CARRERA DE INGENIERÍA EN ELECTROMECAÁNICA

**TRABAJO DE TITULACIÓN PREVIO A LA OBTENCIÓN DEL TÍTULO DE INGENIERO
EN ELECTROMECAÁNICA**

**ENTRENAMIENTO VIRTUAL PARA LA OPERACIÓN Y MANTENIMIENTO EN
LÍNEAS ENERGIZADAS**

Autoras:

Moreno Iza, Erika Fernanda
Pacheco Riera, Evelyn Elizabeth

Dr. Andaluz Ortiz, Víctor Hugo. PhD, *Director*
Ing. Mullo Quevedo, Álvaro Santiago, *Codirector*

