



Artificial Vision and IoT for Automation of Remote Reading for Limnimeters in Hydraulic Weirs

Alex Darío, Chilibingua Chilibingua y Ronald Josué, Garcés Llerena

Departamento de Eléctrica y Electrónica

Carrera de Ingeniería en Electrónica e Instrumentación

Artículo académico, previo a la obtención del título de Ingeniero en Electrónica e Instrumentación

Ing. Rivas Lalaleo, David Raimundo PhD.

22 de julio del 2022

Artificial Vision and IoT for Automation of Remote Reading for Limnimeters in Hydraulic Weirs

Alex Chilibuinga-Chilibuinga, Ronald Garcés-Llerena, Víctor Bautista-Naranjo, and David Rivas-Lalaleo

Grupo de Investigación en Sistemas Inteligentes (WiCOM-Energy), Departamento de Eléctrica y Electrónica, Universidad de las Fuerzas Armadas ESPE, Sangolquí, Ecuador

{[adchilibuinga1](mailto:adchilibuinga1@espe.edu.ec), [rjgarces](mailto:rjgarces@espe.edu.ec), [vrbautista](mailto:vrbautista@espe.edu.ec), [drrivas](mailto:drrivas@espe.edu.ec)}@espe.edu.ec
<http://www.espe.edu.ec>

Abstract. The measurement of flow in a hydraulic weir with a limnimeter is very important to adequately distribute the vital liquid for uses such as irrigation and human consumption. These measurements by intrusive methods are usually costly, time consuming and even with that investment it is sometimes not enough to ensure reliable results. Water level changes are difficult to measure manually because they are not repetitive due to the climatic variability generated in the places where these weirs are located. This work presents a non-invasive image processing and segmentation system, based on artificial vision and IoT, that ensures the detection and measurement of flow in a hydraulic weir over space and time. Tests developed in different environmental conditions during the course of the day, show a more efficient measurement with an error of less than $\pm 2\%$ and a rate of 6 samples/hour.

Keywords: Limnimeter, Hydraulic Weir, Artificial Vision, IoT

1 Introduction

Humanity's sustainable development has essentially depended on water resources and related ecosystems, but at the same time their excessive use has led to their inevitable deterioration [1]. Without proper management of these resources, it is estimated that by 2025, two thirds of the world's population will experience problems of severe or moderate water scarcity [2]. To protect, conserve and properly manage this important part of the biosphere, it is necessary to use new and more efficient irrigation technologies that mean less waste and optimization of the resource [3-9]. In this context, the flow measurement in a hydraulic weir with a limnimeter, is very important to make an adequate distribution of the vital liquid in common uses such as irrigation, human consumption, industrial uses, fish farming, thermal and watering places [1], so a large amount of data and variables related to obtaining flow are needed so that it is not wasted inappropriately [10], but the irregularity of the variations of the water surface level, do

not allow to determine an exact value of measurement and presiding over this information is very difficult because of the difficulty to obtain it in very remote areas, by the limited staff, which performs the measurement manually in random periods of time, so there is a great loss of data. In addition, if expensive flotation systems and sophisticated flow measurement and transmission instruments are used, there is a risk that they may be stolen from the data acquisition site, due to the low level of security in the areas where the hydraulic weirs are located.

In Ecuador there are several investigations and projects related to flow measurement in hydrographic basins. For example, in the research “Metodología para la estimación de caudales mínimos de una cuenca hidrográfica con escasa información hidrometeorológica”, the water balance method and the General Duration Curve (CDG) method are used for the estimation of minimum flows in a basin with scarce hydrological information, whose limitation is the few hydrological stations that are in operation and that keep representative records of flows [11]. In the project “Implementación del Modelo Hidráulico HEC GeoRAS en la Modelación Hidráulica del Sistema para el Control de Inundaciones de los ríos Cañar y Bulubulu”, the GEO module is incorporated into the HEC RAS accompanied by liquid gauging sampling campaigns for the use of georeferenced information from the existing cartography of the area, where one limitation is the unfavorable geographical situation due to the adverse effects of the climate in the area [12]. In the project “Diseño de curvas de gasto en puntos de interés a través de un modelo hidráulico en el río Casacay”, several research methodologies are projected for the recording of limnimetric readings, calculation of hydraulic parameters and the hydraulic mathematical model, limited by the lack of a continuous gauging campaign record [13]. In other regions, water level measurements are supported by different techniques depending on flow specifications, conditions and purposes [14]. For example, authors Loizou and Koutroulis presented a capacitive water level measurement system equivalent to an ultrasonic water level detection device, but which is not suitable for transportation, installation, and long-term maintenance in multiple large-scale water storage tanks [15]. There are also other non-contact methods, such as the measurement of water surface topography by laser scanning, which allows capturing data with high spatial and temporal resolution, but the water specularly reflects the laser beams and this limits the applicability of the method [16]. Finally, there is level measurement using high frequency electromagnetic sensing techniques for liquid level measurement with a small surface area, but there are more complex characteristics compared to an experiment with an infinite surface area, so it is necessary to use shielded sensors with a limited aperture to focus the field to the liquid [17].

In this work, an electronic continuous monitoring system based on artificial vision and IoT is presented. A camera with night vision connected through a communication protocol to a microcomputer, performs a continuous video recording of a limnimeter inside a hydraulic weir to perform the processing of the linear scale that measures the variations of the water surface level, and according to this value ensures the detection and measurement of the flow at that instant.

For the treatment of the video images, different filters are used that allow the processing and segmentation of the captured images and the processed data are sent through a connectivity module by a wireless network in which the information coming from the transmitter is stored and downloaded by means of a server application that allows the user to verify the amount of flow of the weir and its status with respect to the characteristics obtained from the processed data. The designed instrument has a measurement error of less than $\pm 2\%$ and a rate of 6 samples/hour.

2 Methodology

Within Latin America, water represents 28% of the planet's water resources, which are not distributed homogeneously. In Ecuador there are 31 hydrographic systems, which are made up of 79 basins. Of these systems, 48.07%, i.e. 24 hydrographic systems, correspond to two watersheds that originate in the Andes and drain into the Pacific Ocean, 51.41%, corresponding to 7 hydrographic systems, in the Eastern region, and 0.52% corresponds to a hydrographic system in the Insular region [18].

The gauging stations are responsible for obtaining the flow of the river at any given moment and use the limnometric method that allows measuring a height of water and then converting it into an estimate of flow. The technical data recording personnel must place the limnimeter at a sensitive point, submerging the lower end of the instrument in the water and recording the height on a document. Generally, this process should be performed about three times a day, at 6 a.m., 12 (noon), and 6 p.m. in order to obtain a daily record [19]. This method is used in 80% of the measurements at present [20], as they do not require an engineering study, their installation is easy, they have low maintenance costs, and they do not require filtering systems and sludge or sediment traps to ensure their reliable operation. Their main drawback is that they do not allow automated recording of the river water level [18]. In addition, in order to carry out these daily flow gauges, it is necessary for personnel to work in places of difficult access and sometimes with stormy weather, so that for years the possibility of having electronic systems for measuring water level and flow, with high accuracy and reliability, has been limited by the high cost involved. In Ecuador there are still limitations in the availability of hydrometric data, despite the efforts of the National Institute of Meteorology and Hydrology (INAMHI). For example, there is an absence of flow data in the Portoviejo basin, at the Chico AJ Portoviejo station and in the Babahoyo sub-basin belonging to the Guayas basin, at the Embarcadero EN H.CLEM (Pot-Sta. Rosa) station, which in their 25 and 26 year periods, respectively, show 32% and 46.12% of data absence [18].

Since most watersheds are not instrumented, indirect methods are often used to estimate flow for some projects. For example, the cities of La Troncal, El Triunfo and Naranjal, which are located on the lower basins of the Bulubulu and Cañar rivers, suffer from flooding due to their unfavorable geographic location and the adverse effects of the area's climate, which constantly threatens them.

For this reason, a HEC-GeoRAS hydraulic model was implemented accompanied by liquid gauging sampling campaigns that allow us to know the hydraulic behavior of the rivers and not only predict expected levels in the riverbeds, but also to identify possible risk areas in order to take preventive measures [12]. In the province of El Oro, in the canton of Portovelo, the sub-basin of the Luis river is located, which is part of the Puyango river basin. The minimum flows are supplied by groundwater, so it is important to have a fluvimetric station that keeps periodic flow records to determine them. However, in Ecuador, few hydrological stations are in operation and keep representative flow records, so a methodology for the estimation of minimum flows is developed, based on two methods: the water balance method and the General Duration Curve method [11]. Canton Pasaje, Canton Chilla and Casacay Parish, which are located on the Casacay river sub-basin, do not have a record of gauging campaign to know in the future how much quantity and use of water can be given to the riverbed. For this purpose, several research methodologies were projected, such as: gauging methods, registration of control points in each gauging station, registration of limnimetric readings, calculation of hydraulic parameters and the hydraulic mathematical model [13].

All these projects have in common the manual measurement of a limnimetric scale inside a hydraulic weir, either natural or artificial, where the water level is recorded in centimeters. This level value must be transformed into flow rate, by means of a specific equation depending on the selected weir. Table 1 presents some weir and orifice methods, column 1 specifies the type of weir, column 2 the equations for each weir to obtain its flow rate and column 3 the design of the weir.

The objective of this work is to use a camera with night vision connected through a communication protocol to a microcomputer to continuously record the water level measured by the limnimeter of one of the weirs in Table 1, to internally process and segment the level values and transform them to flow rate. A 20-second recording is made every 10 minutes, the information is processed after 1 minute and a rate of 6 samples/hour is obtained as a result. Then the flow rate data is sent through a connectivity module based on the LoRaWAN network protocol to the IoT server, which records the information and downloads it to a server application for the user to verify the amount of flow rate of the weir.

3 Solution Architecture

This section describes the system design, presents the devices and technologies used to design the electronic system for data acquisition, image processing, transmission and storage of flow information of a hydraulic weir, as well as the communication, IoT platform and the power generation system with solar panels. Also, each of the subsystems implemented and fully operational is described. The system for the automation of remote reading of limnimeters in hydraulic weirs is integrated by the following subsystems: power supply and energy storage system, microcomputer, devices with LoRa communication and IoT platform.

Table 1. Weir and orifice methods

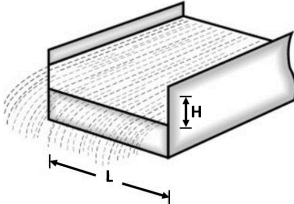
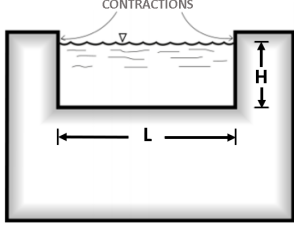
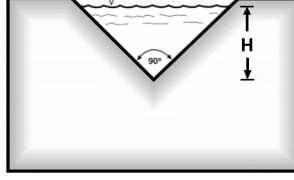
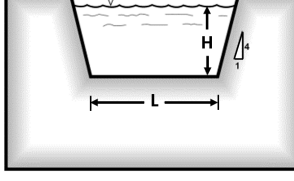
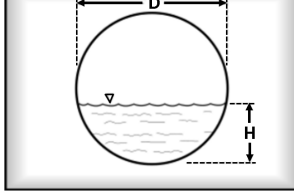
Weirs	Equation	Design
Rectangular weir without contractions	$Q^a = 1.84L^b \times H^{c3/2}$	
Rectangular weir with two contractions	$Q = 1.84L(L - 0.2H) \times H^{3/2}$	
Triangular weir	$Q = 1.4 \times H^{5/2}$	
Trapezoidal weir	$Q = 1.859 \times L \times H^{3/2}$	
Circular weir	$Q = 1.518 \times D^{d0.693} \times H^{1.807}$	

^aFlow rate (m^3/s)^bCrest length (m)^cWeir load (m)^dDiameter of circle (m)

The system design was implemented according to the flow diagram in Fig. 1. Once the array is powered by the photovoltaic system, the camera starts recording the water level variations over the limnimeter inside the hydraulic weir, the recording is transmitted to the microcomputer that processes the video images, obtaining as a result the flow rate of the weir in l/s to then send this information through the devices with LoRa communication to the IoT platform and download the data to a server application that allows the user to check the flow rate value of the weir every 10 minutes. Fig. 2 shows the schematic design including the elements used in the system for automation of remote reading for limnimeters in hydraulic weirs: solar panel, solar charge controller, battery, DC/AC inverter, microcomputer, camera, LoRa communication devices, IoT server. Fig. 3 shows a rectangular weir without contractions used as a reference for remote reading automation of its embedded limnimeter.

3.1 Video Image Digitization

Once the camera starts recording the limnimeter, the microcomputer performs video image processing based on thresholding in Hue, Saturation, Value (HSV) color space, set intersection and based on Otsu's algorithm [21], to obtain an optimal threshold value based on the input images. Fig. 4 shows the implementation of a digital ruler to measure the limnimeter water level, based on the understanding of horizontal segments, vertical segments, diagonals and an end-point positioning. Each contour is stored as a vector of points and you obtain an output vector that has information of the topology of the image. Finally, a specific contour area is calculated and the detected water level is transformed into flow rate by means of the equation of the rectangular weir without contractions.

3.2 Radio Link Study

The previous study of the radio link source signal from point A to point B using the Radio Mobile simulator is presented in Fig. 5. The distance traveled is 3,141 km, using a LoRa 32 WiFi transmitting antenna based on ESP32 and LoRa SX127x which is placed at a height of 2 m and a receiving antenna with the same characteristics placed at 1.7 m, transmitting at a frequency of 830 MHz adapted to the specific limits for international transmitters and Industrial, Scientific and Medical (ISM) equipment applications [22]. As can be seen in Fig. 5a, between points A and B there is a green line that identifies a correct signal reception, without considerable losses. Fig. 5b shows the communication parameters, with a relative reception of 40.3 dB above the upper limit required for communication and with total signal losses of 123.1 dB, composed by 101.3 dB of free space losses, 15.2 dB of losses due to obstructions and 6.6 dB of static losses. Three caution points are identified, indicating the number of locations with alerts where considerable signal attenuation may occur, such as at coordinate 01°21'26.6 "S 078°35'29.7 "W, where the signal value reaches its highest point of attenuation, but is within the lower signal limit required for reception.

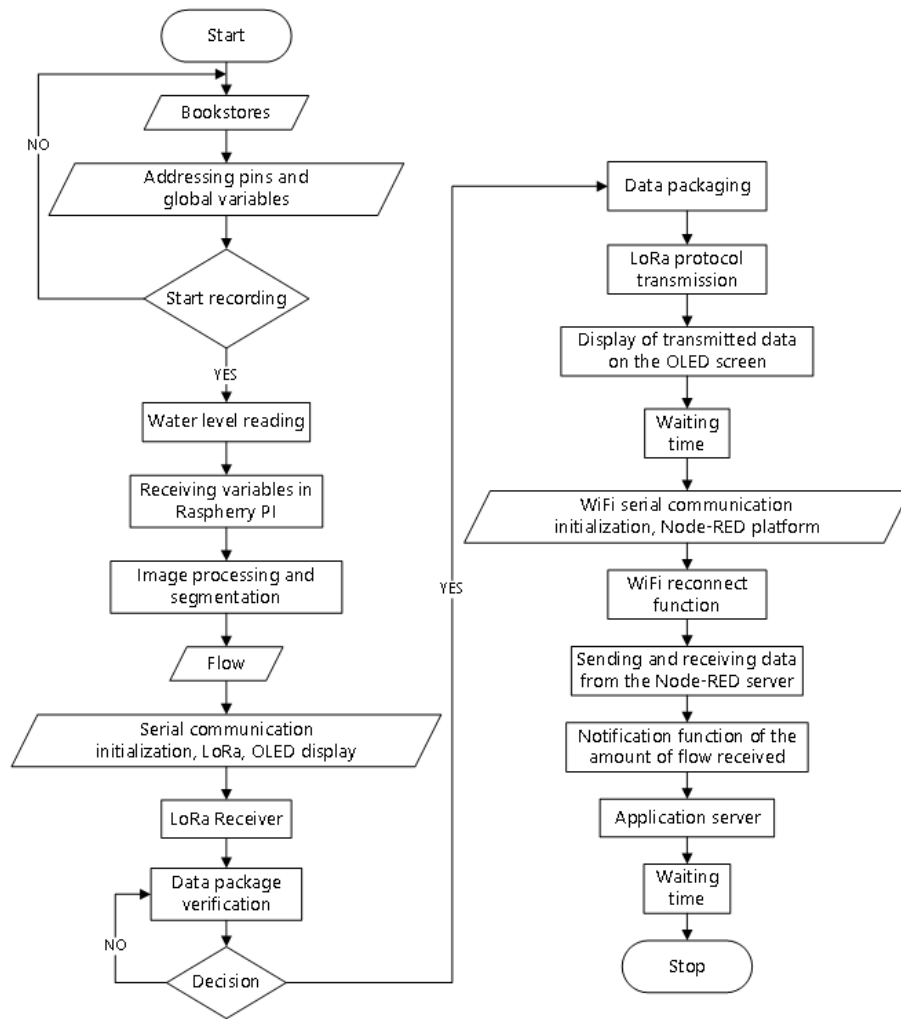

Fig. 1. System flow diagram for automation of remote reading of limnimeters on hydraulic weirs

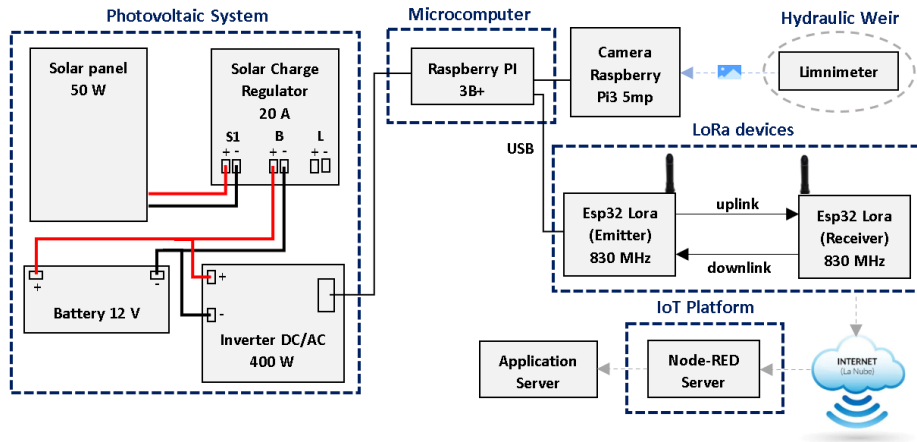

Fig. 2. Schematic design of the system for the automation of remote reading of limnimeters in hydraulic weirs

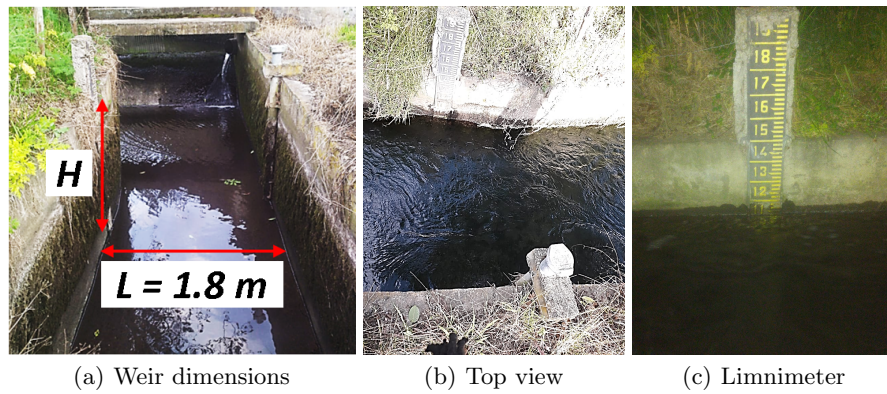

Fig. 3. Rectangular weir without contractions

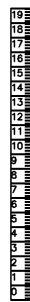
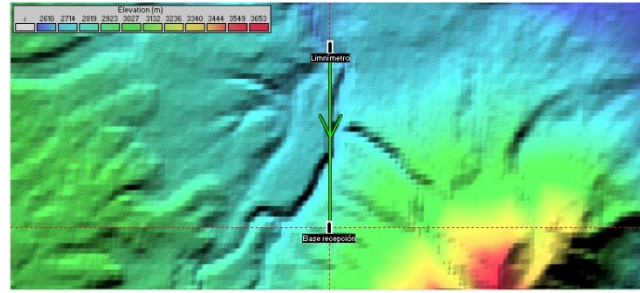
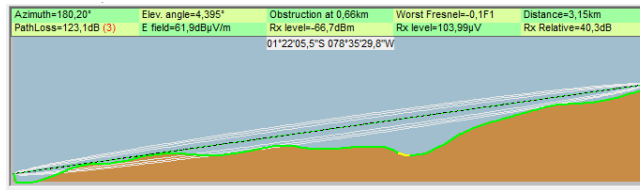

Fig. 4. Digital ruler



(a) Limnimeter-reception base connection network



(b) Radio link

Fig. 5. Radio link using Radio Mobile

3.3 IoT Platform

The coding of the Node-RED program to connect the devices with LoRa communication as part of IoT in addition to recording and storing the flow data obtained from the hydraulic weir is presented in Fig. 6. For the transmission of this data, Mosquitto is used to create the Message Queue Telemetry Transport (MQTT) Broker and send the messages through the concept of subscription and publication, so that the information can be shared and exchanged between smart home devices. The Node-RED information recognition service is used to store the flow data and to obtain the identification result through the emulator. The flow data is sent to the Telegram application that uses a bot, to respond to the instructions provided by the user.

4 Experimentation

This section shows the infrastructure of the system in operation, where the entire assembly described in Fig. 2 is covered by a metal structure from which only the camera lens protrudes for continuous recording of the limnimeter. The solar panel, which is responsible for transforming the sun's energy into electrical energy [23], is placed on a tube 2.5 m above the ground in a northerly direction with an optimum inclination of 15°. The structure presents a great robustness to the climatic changes corresponding to the area as shown in Fig. 7. On the other hand, Fig. 8a and 8b show the continuous recordings of the camera with night vision over the limnimeter and the processing that allows measuring the water level with high precision both during the day and at night.

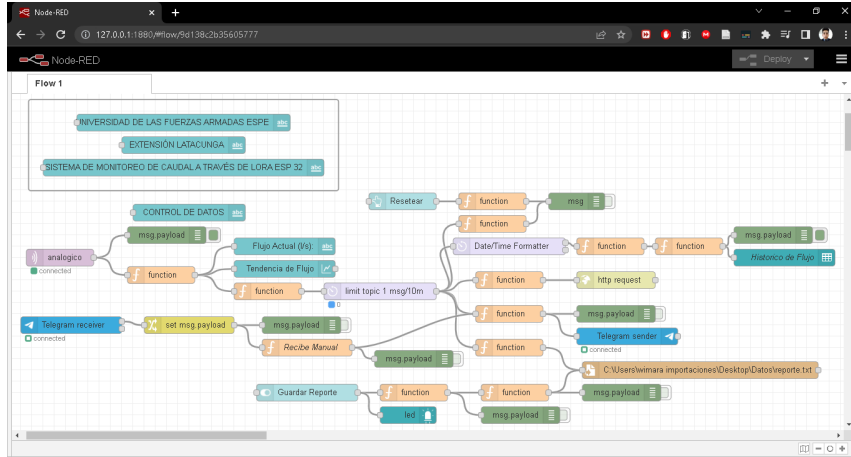

Fig. 6. Node-RED environment

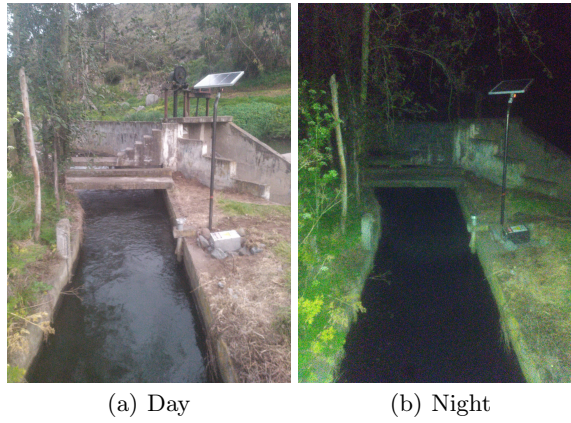

Fig. 7. Operation of the flow monitoring system

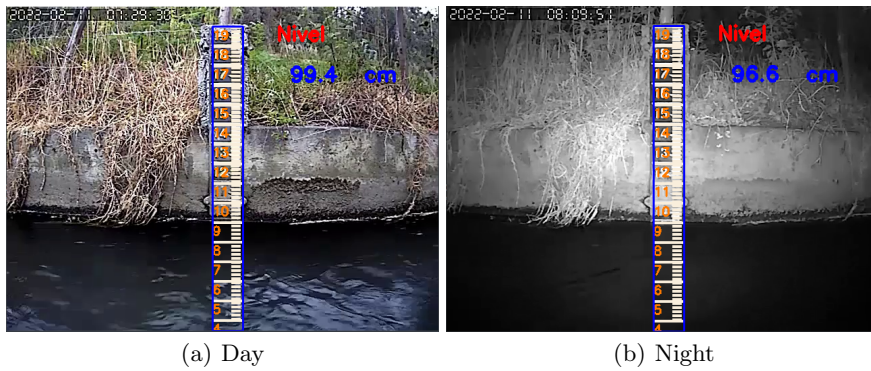

Fig. 8. Limnimeter reading

5 Results

The results were obtained by making a comparison between the manual measurement of the water level of the limnimeter by several people in contrast to the measurement using the electronic system. The manual measurement was performed by 300 people who from their visual perspective recorded a specific level value measured at the time instants described in Table 2, the mode of each of the measurements was obtained and by means of the box and whiskers diagram in Fig. 9, the relationship between the approximation of the manual and automatic data measured at those time instants was obtained. It can be observed that in the samples obtained during the night there is a greater dispersion of data, therefore the error is greater, unlike the data obtained with the designed instrument which, thanks to the incorporation of the camera with night vision, allowed to obtain with greater precision the real value of the water level of the limnimeter and based on this a cumulative error for the electronic system of $\pm 1.1080\%$ was obtained, which indicates a more efficient measurement and an error of less than $\pm 2\%$. In addition, the measurements with the designed instrument present a standard deviation of 0.6497 cm, which indicates that most of the measured data are clustered very close to their expected value and therefore the instrument is more accurate and precise with respect to a manual measurement. The sensitivity of the instrument associated with the water level being measured is ± 0.1 cm, this being the minimum variation that can be detected by the measuring instrument.

Table 2. Water level measurements on the limnimeter

Schedule	07:30	13:30	18:30	21:30	01:30	05:30
Manual Measurement (cm)	108	92	94	112	114	112
Automatic Measurement (cm)	108.21	94.7	95.07	110.54	113.87	112.11
Error (%)	0.19	2.93	1.13	1.3	0.11	0.098

The flow curves for the evaluation of the automated limnimeter remote reading system in the rectangular weir without contractions shown in Fig. 10 present the data taken during a typical day manually and automatically. The blue colored curve represents the measurements taken with the automated flow monitoring system every 10 minutes, the orange colored curve represents the manual measurements taken by 300 people at random times, the red colored chopped curve represents the measurements taken according to the protocol of the limnimetric method and the black colored curves indicate the error range of $\pm 2\%$ within which the designed instrument is located. The manual measurements were obtained at 10 different times of the day, it can be clearly observed how in the period from 7:30-13:30 in contrast with the real data obtained in the automatic measurement, there is an inadequate appreciation of water flow, that if the real data were not available, it would seem as if the water level decreased slowly

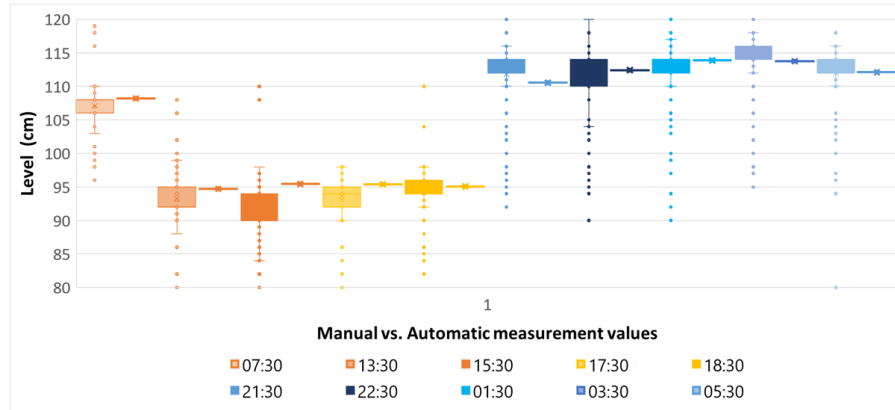

Fig. 9. Box and Whisker Diagram

during that period when in fact the water accumulated constantly until it was used for its various purposes and in the period from 12:00-13:30 was when it really decreased considerably. On the other hand, if we observe the measurement curve made according to the protocol of the limnometric method, we have even more considerable appreciations, especially during the night, where the water accumulated faster than normal, due to external factors such as rain, a manual blockage of the gates of the hydraulic weir or any other factor, but it did not accumulate slowly as its curve indicates.

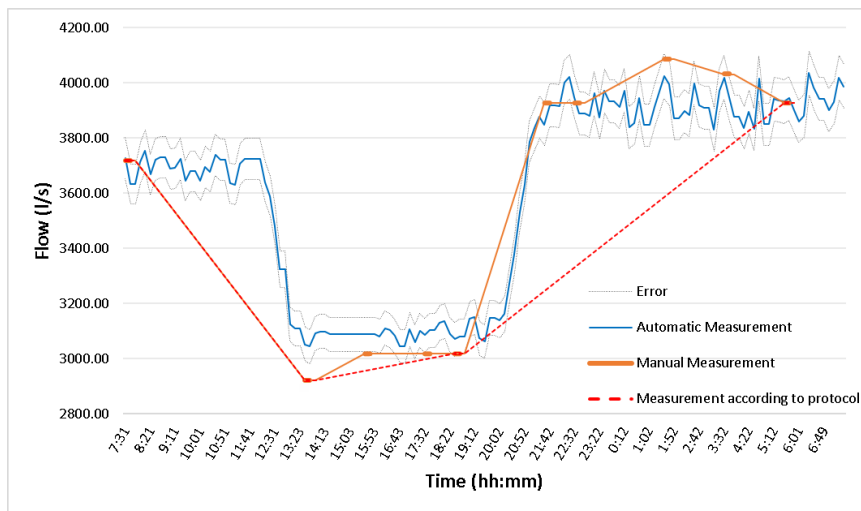

Fig. 10. Nominal flow rate obtained after transmission

From the results obtained it can be concluded that the system meets the LoRaWAN specifications. The Node-RED emulator, shown in Fig. 11, allows observation and analysis of the received packets. Thus, debugging in the Telegram application can be performed seamlessly. The packets sent by the LoRa 32 WiFi development board are correctly received by the server, the information present at the platform level includes the Date/Time and the Flow rate.

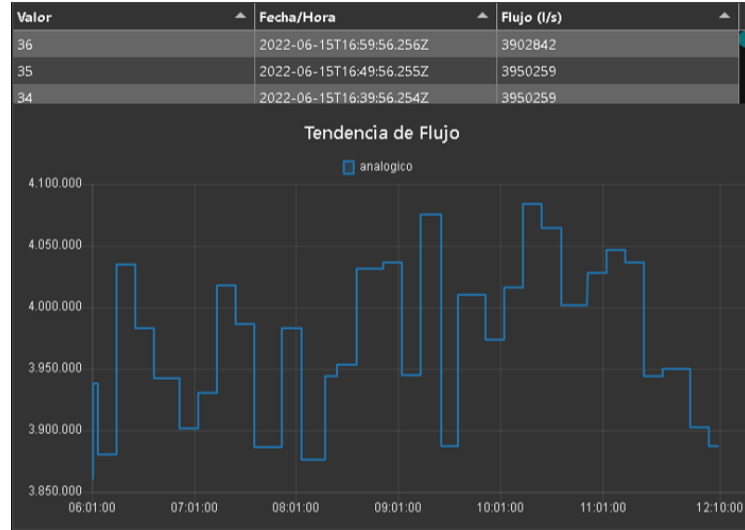

Fig. 11. Flow rate control interface

6 Conclusions

The accumulated error of the measurement with the designed instrument is $\pm 1.1080\%$ which indicates that the efficiency of the automatic measurement is higher than the manual measurement and the error is less than $\pm 2\%$, also, its standard deviation of 0.6497 cm, indicates that most of the measured data are clustered very close to its expected value and therefore the instrument is more accurate and precise. The sensitivity of the instrument in relation to the measured water level is ± 0.1 cm, which is the smallest change the measuring instrument can detect.

The automation of remote reading of limnimeters in hydraulic weirs through artificial vision and IoT, allows the user to verify the amount of flow of the weir with a measurement error of less than $\pm 2\%$ with respect to a visual measurement, in this way a constant monitoring of the water resource is achieved and there is no loss of data at any time. The option of having a complete continuous monitoring system available to all users represents a very significant advance

associated with a wider range of communications and greater data fidelity. In addition, with medium-high devices, technologies and resources, it is possible to obtain an interactive, safe, easy to use and, above all, low cost system compared to other flow measurement systems.

The electronic system implemented allows to obtain as a result the effective flow rate of the hydraulic weir in l/s without the need to directly visualize the linear scale of the limnimeter, consequently, there is less waste and optimization of water, since the necessary data for an adequate distribution of the resource are available.

Based on the results obtained, it can be concluded that LoRaWAN technology represents a practical alternative for applying the IoT concept, as it is a very wide area network with low power consumption. Even though its data rate requires further analysis, its range and energy efficiency satisfactorily compensate for the limitations of this technology.

7 Future Work

It is important to mention that in the present project the information processing is performed inside the remote unit, in order to improve the characteristics of the designed instrument, communication protocols should be analyzed in which video transmission is allowed considering a low transmission rate, long range and low power consumption.

Acknowledgments. This work was supported by the Universidad de las Fuerzas Armadas ESPE and is related to the research projects “Automatización de lectura remota para Limnímetros en Vertederos Hidráulicos a través de visión artificial e IoT”, with the project “Sistema de alerta temprana para la detección de heladas en las provincias de Cotopaxi y Tungurahua”, with the project “Sistema Ciber-Físico de Cuantificación de Impactos para Polígono de Tiro Láser de las Unidades Militares del Ejército Ecuatoriano” and also with the project “SISMO-ROSAS: Sistema de monitoreo para optimizar el ciclo productivo de las rosas”, of the UPS.

References

1. Mendoza, B.G., Santillán, G.P., Tingo, W.J.: ESTUDIO HIDROLÓGICO PARA EL DESARROLLO SOSTENIBLE DE LA INTERCUENCA DEL RÍO AMBATO. La Quinta Ola del Progreso de la Humanidad, Riobamba, Ecuador, pp. 101-102 (2016)
2. GWP: Manejo integrado de recursos hídricos. TAC BACKGROUND PAPERS, Estocolmo, Suecia, pp. 9 (2000)
3. CONGOPE: HABLEMOS DE RIEGO. El Telégrafo EP., Quito, Ecuador, pp. 13 (2016)

4. Vinueza, P.G., Nascimento, H.A., Rumipamba, R., Ruiz, I., Rivas, D., Patil, N.J.: IoT-Based Smart Agriculture and Poultry Farms for Environmental Sustainability and Development. In: Guarda, T., Anwar, S., Leon, M., Mota Pinto, F.J. (eds) Information and Knowledge in Internet of Things. EAI/Springer Innovations in Communication and Computing. Springer, Cham, pp. 379-406 (2022). https://doi.org/10.1007/978-3-030-75123-4_17
5. Chuchico, C., Rivas, D.: Sensor Nodes and Communication Protocols of the Internet of Things Applied to Intelligent Agriculture. In: Botto-Tobar, M., Montes León, S., Camacho, O., Chávez, D., Torres-Carrión, P., Zambrano Vizuete, M. (eds) Applied Technologies. ICAT 2020. Communications in Computer and Information Science, vol 1388. Springer, Cham, pp. 686-703 (2021). https://doi.org/10.1007/978-3-030-71503-8_53
6. Chiluisa, G., Lagla, J., Rivas, D., Alvarez, M.: Intelligent Monitoring System of Environmental Biovariables in Poultry Farms. In: Arai, K., Kapoor, S., Bhatia, R. (eds) Intelligent Systems and Applications. IntelliSys 2020. Advances in Intelligent Systems and Computing, vol 1252. Springer, Cham, pp. 386-399 (2021). https://doi.org/10.1007/978-3-030-55190-2_29
7. Sichiqui, F., Huilca, J.G., García, A., Guillermo, J.C., Rivas, D., Clotet, R., Huerta, M.: Agricultural Information Management: A Case Study in Corn Crops in Ecuador. In: Botto-Tobar, M., León-Acurio, J., Díaz Cadena, A., Montiel Díaz, P. (eds) Advances in Emerging Trends and Technologies. ICAETT 2019. Advances in Intelligent Systems and Computing, vol 1066. Springer, Cham, pp. 113-124 (2020). https://doi.org/10.1007/978-3-030-32022-5_11
8. García, A., Guillermo, J.C., Barzallo, B., Punin, C., Soto, A., Rivas, D., Clotet, R., Huerta, M.: PLATANO: Intelligent Technological Support Platform for Azuay province Farmers in Ecuador. 2019 IEEE International Conference on Engineering Veracruz (ICEV), pp. 1-7 (2019). <https://doi.org/10.1109/ICEV.2019.8920501>
9. Guillermo, J.C., García, A., Rivas, D., Huerta, M., Clotet, R.: IoT Architecture Based on Wireless Sensor Network Applied to Agricultural Monitoring: A Case of Study of Cacao Crops in Ecuador. In: Corrales, J., Angelov, P., Iglesias, J. (eds) Advances in Information and Communication Technologies for Adapting Agriculture to Climate Change II. AACC 2018. Advances in Intelligent Systems and Computing, vol 893. Springer, Cham, pp. 42-57 (2019). https://doi.org/10.1007/978-3-030-04447-3_3
10. Universidad de Cuenca, <https://www.ucuenca.edu.ec/idrhica/index.php/es/pronostico-hidrologico/>
11. Sánchez, C., Vera, F., Luna, A., Espinoza, J., Bustamante, A., Cárdenas, J., Lucero, W.: Metodología para la estimación de caudales mínimos de una cuenca hidrográfica con escasa información hidrometeorológica. Cumbres, Machala, Ecuador, pp. 143-149 (2017)
12. Encalada, J.R., Jara, R.D.: Implementación del Modelo Hidráulico HEC GeoRAS en la Modelación Hidráulica del Sistema para el Control de Inundaciones de los ríos Cañar y Bulubulu. UCUENCA, Cuenca, Ecuador, pp. 10-12 (2010)
13. Salazar, W.F.: DISEÑO DE CURVAS DE GASTO EN PUNTOS DE INTERÉS A TRAVÉS DE UN MODELO HIDRÁULICO EN EL RÍO CASACAY. UTMACH, Machala, Ecuador, pp. 1-3 (2019)
14. Isidoro, J.M., Martins, R., Carvalho, R.F., de Lima, J.L.: A high-frequency low-cost technique for measuring small-scale water level fluctuations using computer vision. Elsevier, Portugal, pp. 1-2 (2021). <https://doi.org/10.1016/j.measurement.2021.109477>

15. Loizou, K., Koutroulis, E.: Water level sensing: State of the art review and performance evaluation of a low-cost measurement system. *Measurement*, pp. 1-28 (2016). <http://dx.doi.org/10.1016/j.measurement.2016.04.019>
16. Rak, G., Hočevár, M., Steinman, F.: Measuring water surface topography using laser scanning. Elsevier, Slovenia, pp. 35-44 (2017). <http://dx.doi.org/10.1016/j.flowmeasinst.2017.07.004>
17. Yang, T., Zhao, Q., How, K.Y., Xu, K., Lu, M., Xie, Y., Yin, W.: Level Measurement for Saline with a Small Surface Area Using High Frequency Electromagnetic Sensing Technique. *Measurement*, pp. 1-18 (2017). <http://dx.doi.org/10.1016/j.measurement.2017.01.025>
18. Muñoz, Á.G., Macías, S., García, M.B.: INFORME FINAL DE CARACTERIZACIÓN HIDROLÓGICA. Ministerio de Ambiente, Quito, Ecuador, pp. 8-65 (2014)
19. Canchi, M.E.: DISEÑO Y PLANIFICACIÓN DE UN LABORATORIO DE HIDROLOGIA PARA LA UNIVERSIDAD CENTRAL DEL ECUADOR. UCE, Quito, Ecuador, pp. 34 (2013)
20. Abdelkader, L.J.: ANÁLISIS Y COMPARACIÓN DE METODOLOGÍAS DE AFORO DE CAUDAL EN LÁMINA LIBRE MEDIANTE CURVA DE GASTO Y PERFILADOR ACÚSTICO DOPPLER. APLICACIÓN EN RÍOS DE LA REGIÓN DE QUEBEC (CANADÁ). Universidad Politécnica de Valencia, Valencia, España, pp. 10-11 (2012)
21. Otsu, N.: A Threshold Selection Method from Gray-Level Histograms. *IEEE Transactions on Systems, Man, and Cybernetics*, pp. 62-66 (1979). <https://doi.org/10.1109/TSMC.1979.4310076>
22. CODELECTRA: NORMALIZACIÓN EN ENERGÍA EÓLICA. Boletín Informativo Trimestral, Caracas, Venezuela, pp. 1-14 (2011)
23. Abella, M.A.: Sistemas fotovoltaicos. CIEMAT, SAPT Publicaciones Técnicas, SL., Madrid, España, pp. 3 (2005)