



*Vocabulario en  
imagenes*



### ***Instrucciones de uso y propósito del vocabulario***

El vocabulario de imágenes recoge más de 200 términos de uso común para niños pequeños considerando básico en el idioma castellano por muchos especialistas del área, que suelen formar parte de los conocimientos y las experiencias que los niños y niñas normales son capaces de ir asimilando en torno a los 2 años.

Para su mejor aprovechamiento ha sido organizado en redes semánticas agrupadas en cinco categorías / series de contenido.

#### ***El cuerpo y los vestidos:***

Abrigo, boca, bota, botón, cabeza, calcetín, camisa, etc.

#### ***Personas y otros objetos relacionados:***

Abanico, abrazo, abuela/o, agua, aguja, ajo, etc.

#### ***Hogar y ambiente doméstico:***

Aguja, armario, bombilla, cama, etc.

#### ***Animales y naturaleza:***

Abeja, ala, araña, ardilla, búho, burro, etc.

#### ***Trasportes y objetos comunes y diversos:***

Arpa, autobús, avión, balón, bandera, barco, etc.



1b



1c

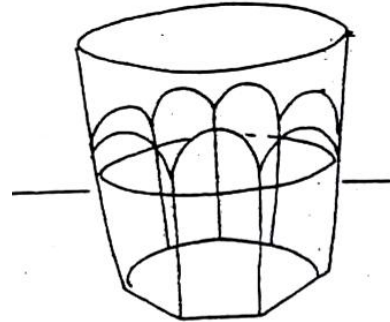

1e

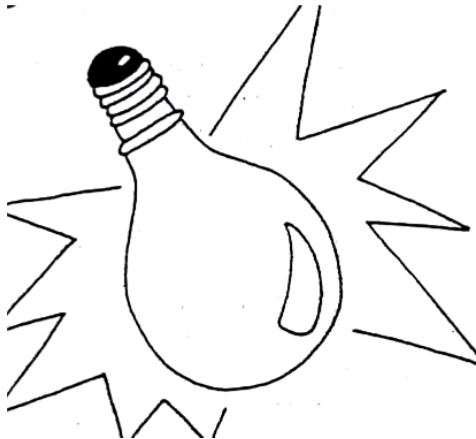

2e



3e



4e

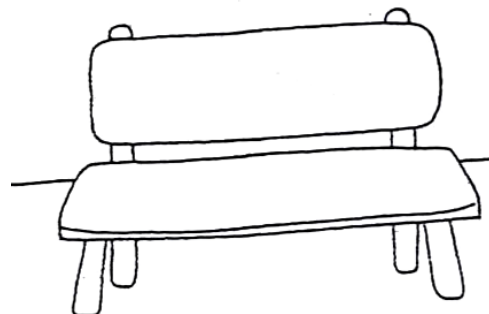



5e

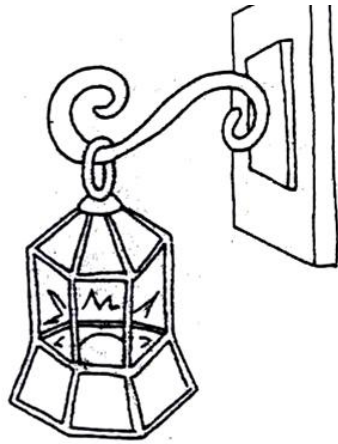

2b



1a

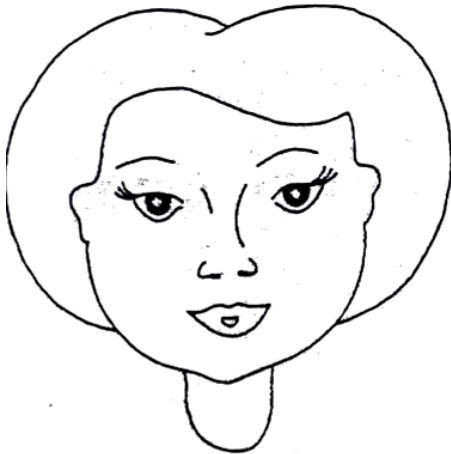

6e

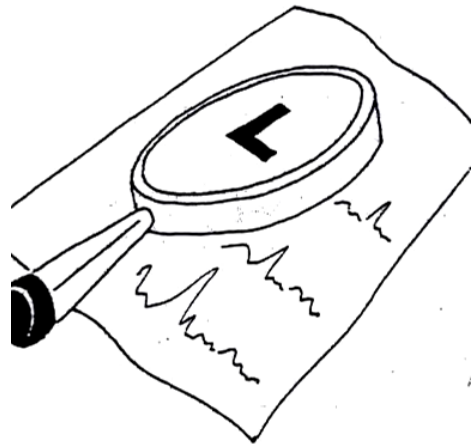

7e

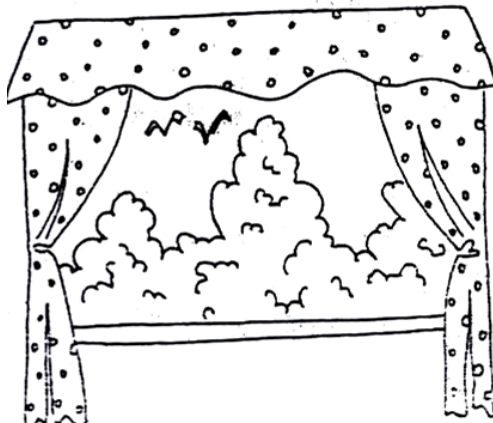

8e

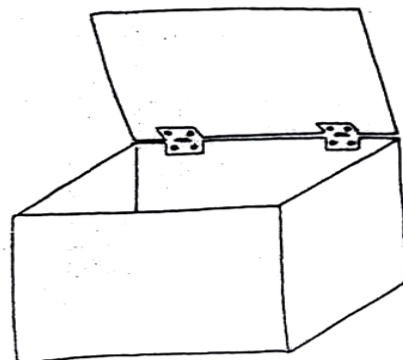



9e



1b



10e



2a

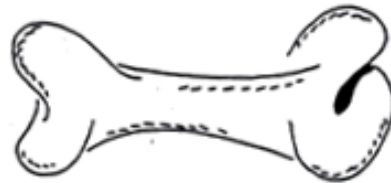

2b

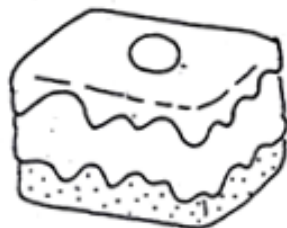

11e





4b



5b



12e

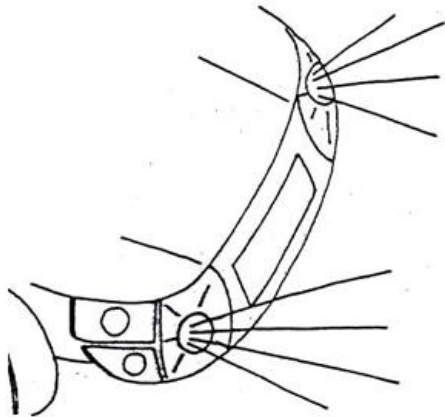

6b



3<sup>a</sup>

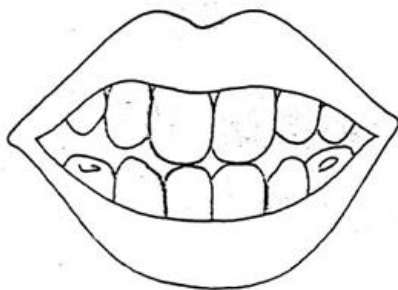

7b





2d



3d



4d



5d



8b



13e





9b



14e



15e



16e



10b



17e







11b



12b

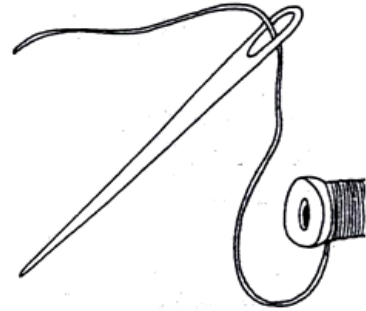

18e



13b



2c



14b





15b



19e

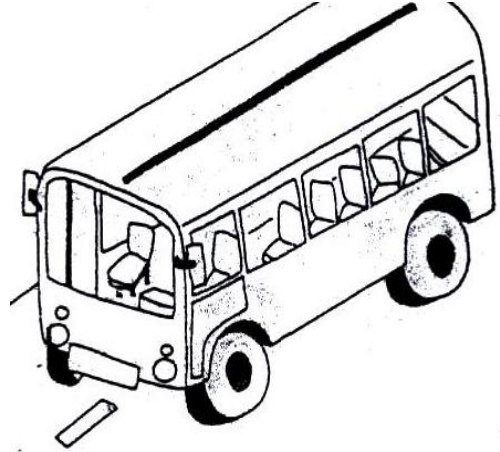

20e



16b



6d

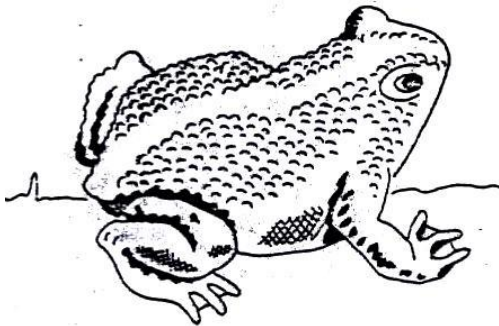

17b

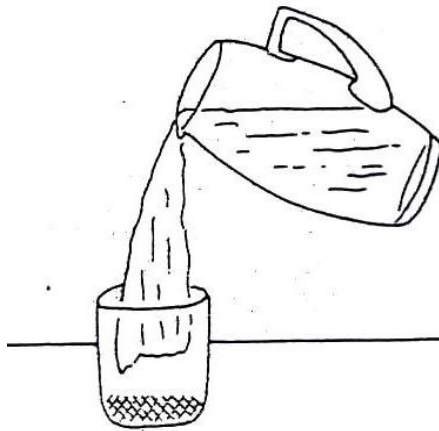



8b



19b



7d



21e



20b



22e

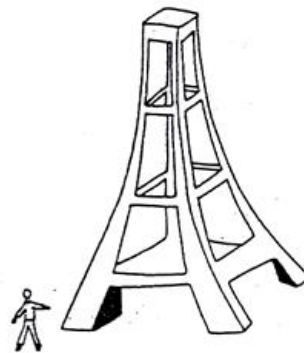



21b



4a

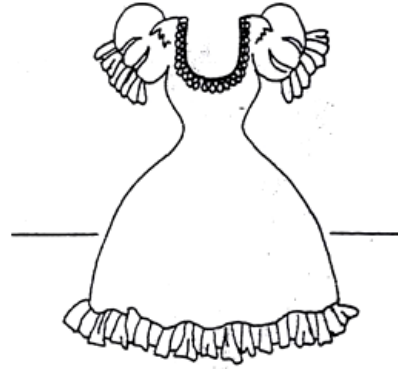

3c

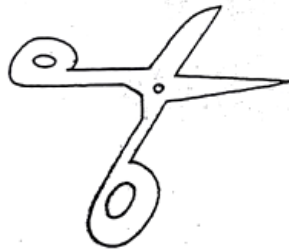

22b



23b



23e

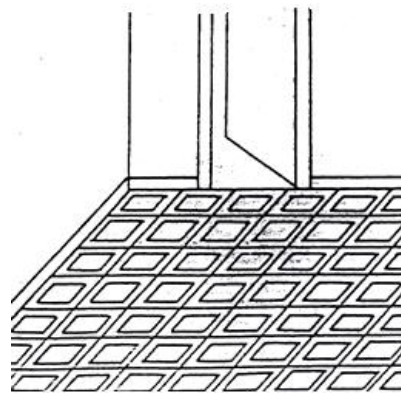



4c



5a

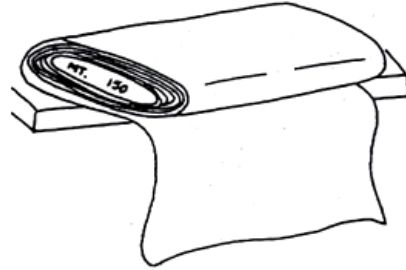

24e



6a



25e



26e

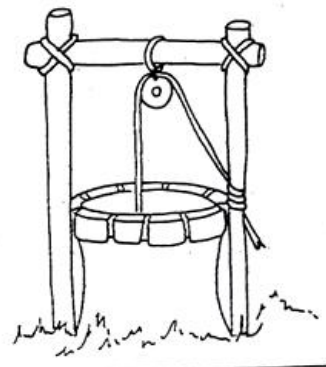



8d



9d



7a

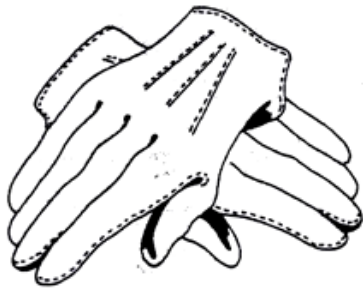

5c

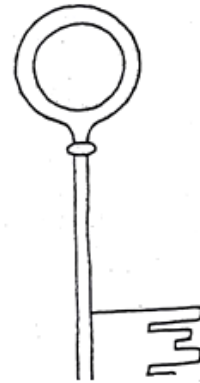

8a



10d

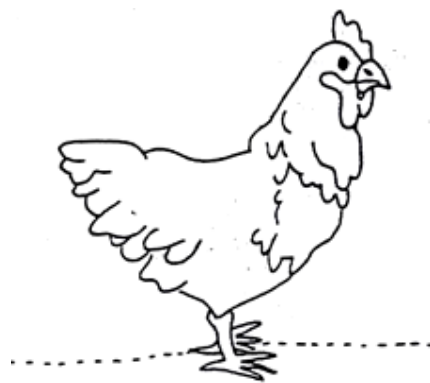



24b

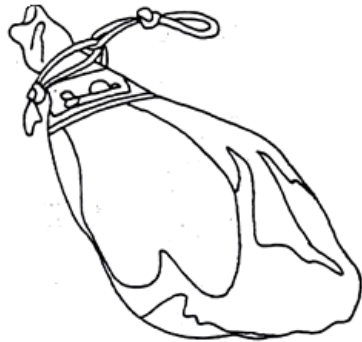

11d



12d



27e

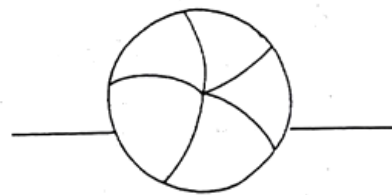

28e

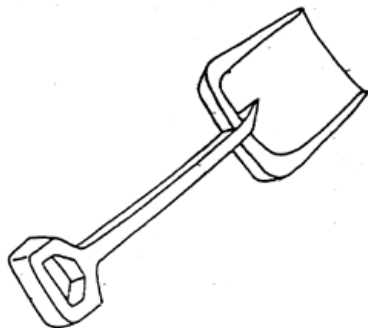

29e





31e

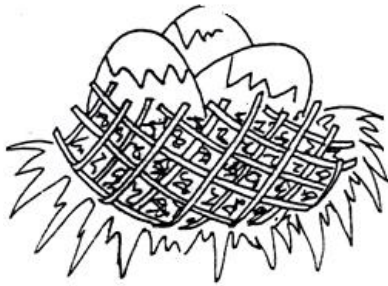

32e



33e

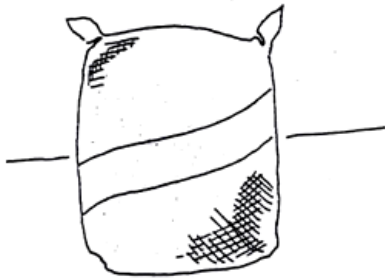

28b



29b



9a







3e



25b



26b

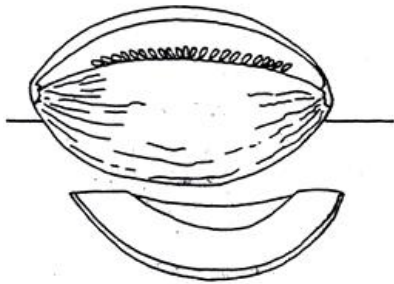

30e

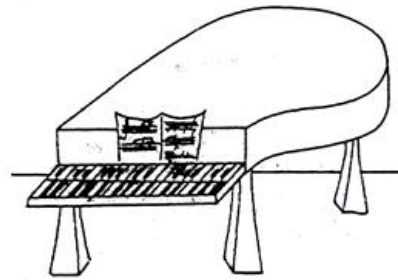

14d



27b





15d



34e



30b



31b



35e

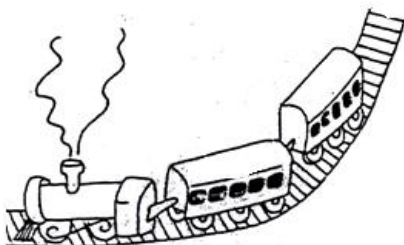

32b

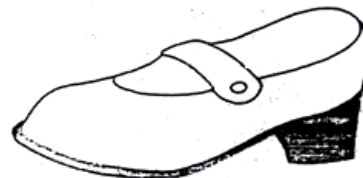



6c



33b



16d



17d

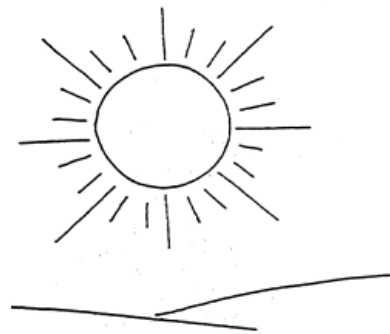

18d



34b

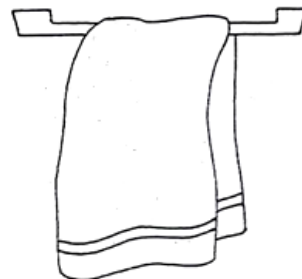



36e

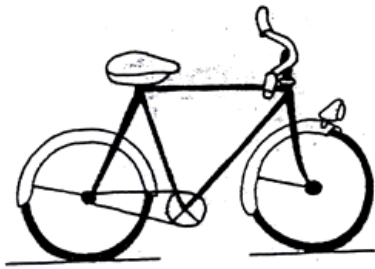

19d

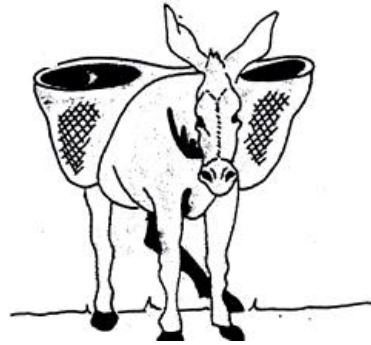

7c



37e

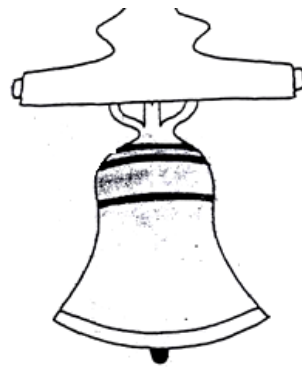

38e

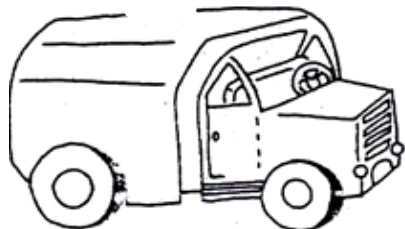

8c





9c

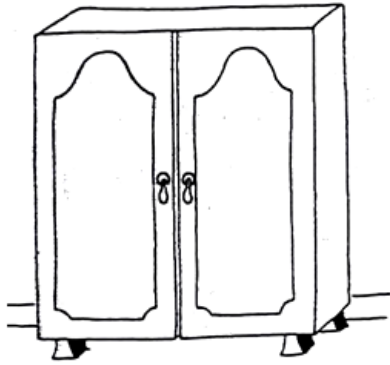

39e

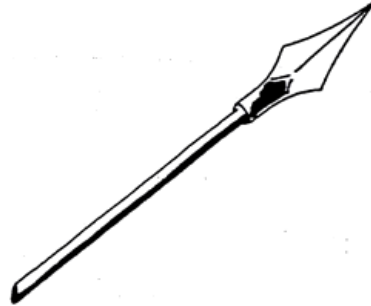

35b



36b



10a



37b





38b

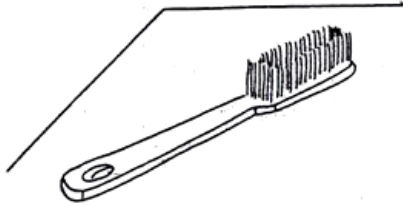

40e



20d



41e

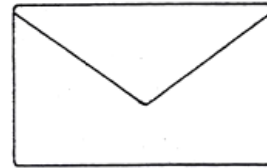

42e

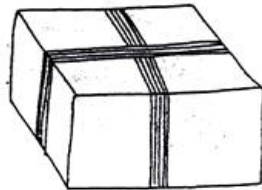

21d





22d



11a



43e



23d

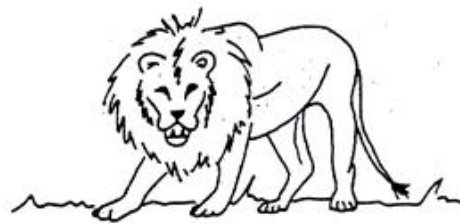

44e



12a





42b



15a



43b



47e

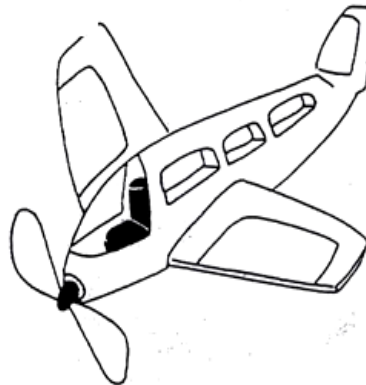

48e

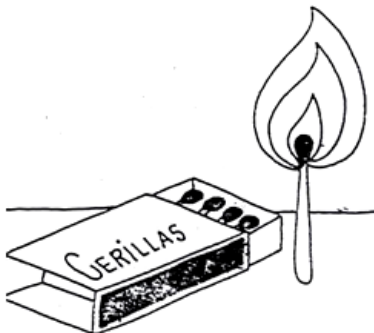

10c







24d

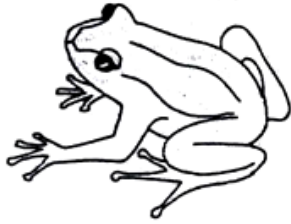

49e



44b



16a



45 b



17a





11c

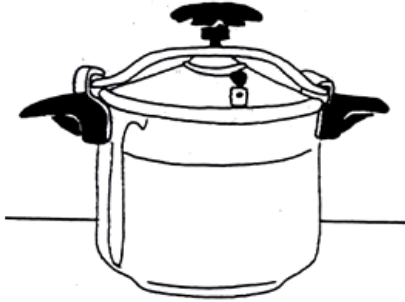

50e



46a

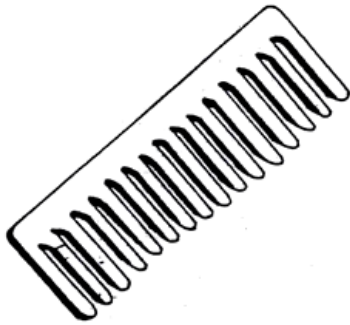

25d

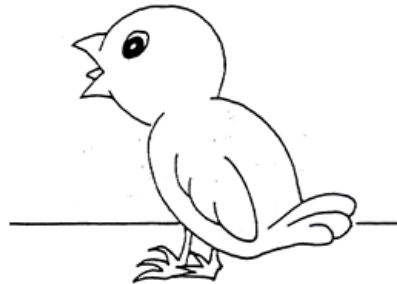

12c

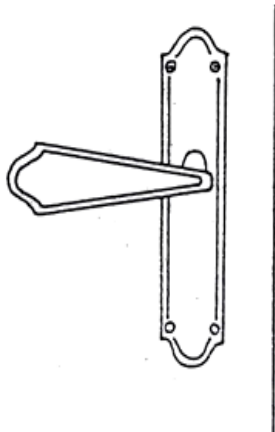

51e

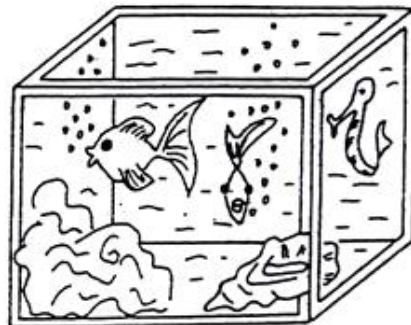



52e

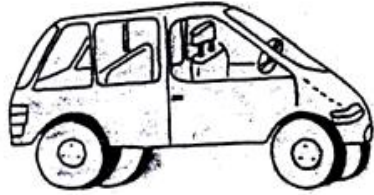

26d

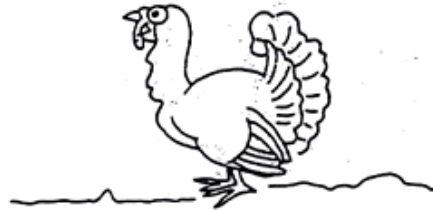

18a

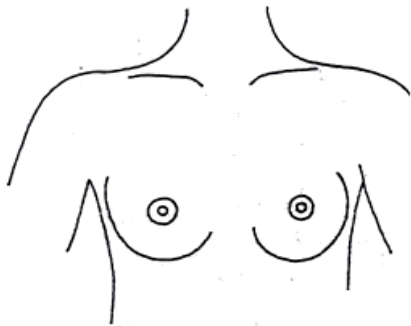

53e

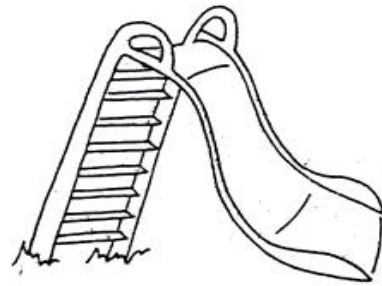

13c

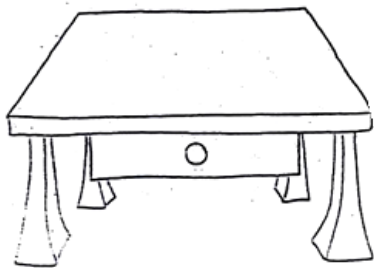

47b

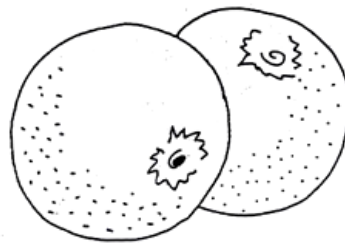



48b

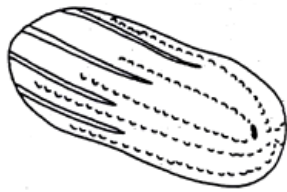

27d



54e



49b



28d



55e

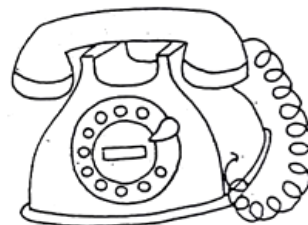



50b



15c



56e



51b



19a

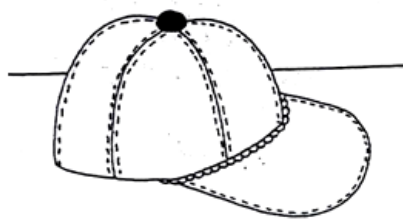

57e

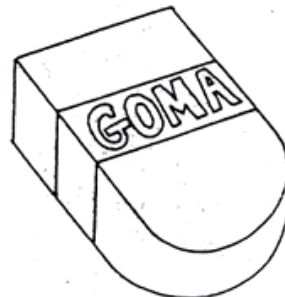



29d



52b



16c

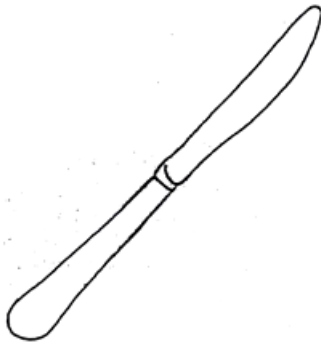

20a



21a



17c





30d

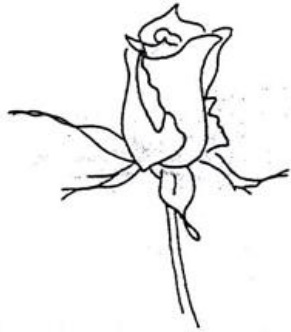

58e



22a

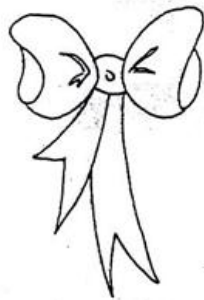

31d

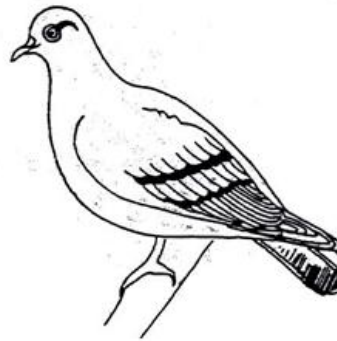

59e



18c





53b



19c



20c

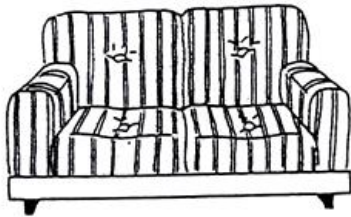

32d



60e



33d

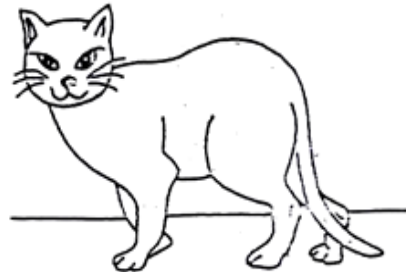





34d

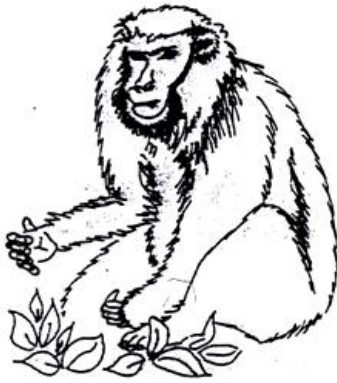

61e

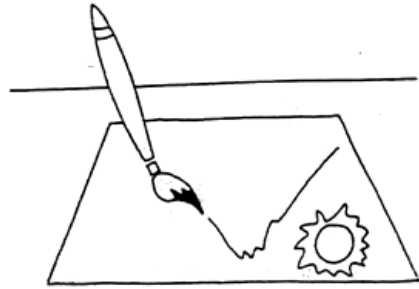

21c

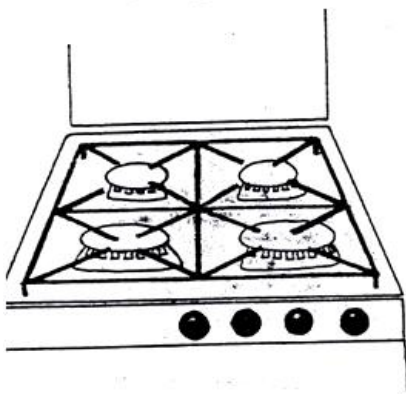

35d



54b



22c





36d

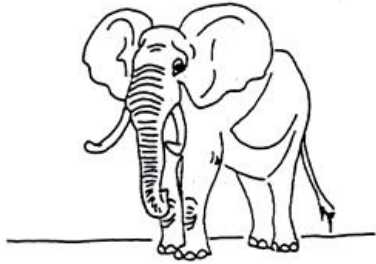

62e

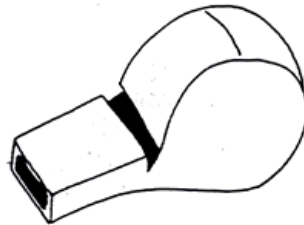

23a



24a

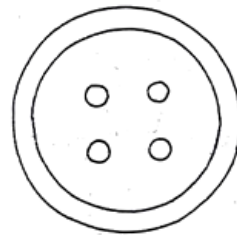

37d



23c

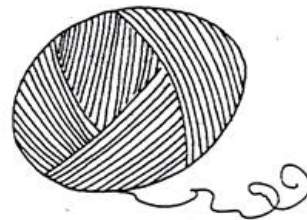



25a



38d



63e



24c



39d

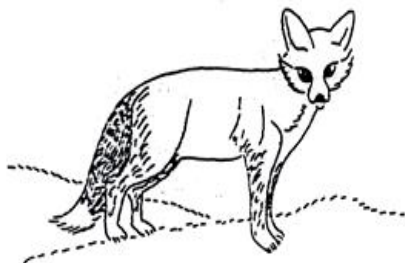

64e





65e



25c

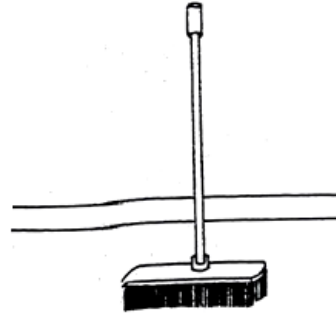

66e



40d

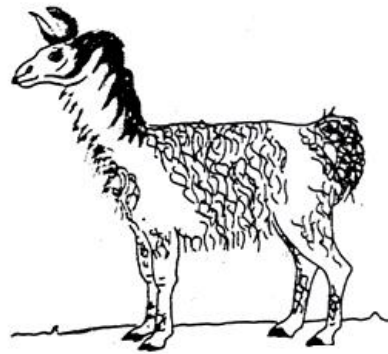

41d

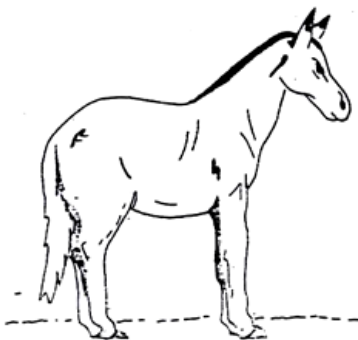

55b

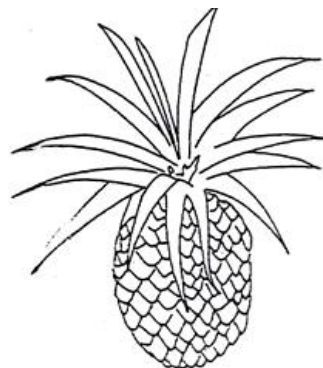



42d

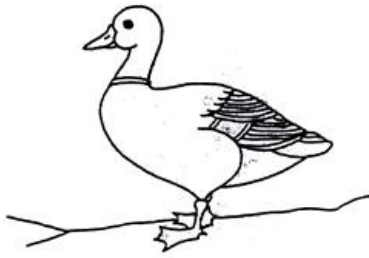

26c



67e

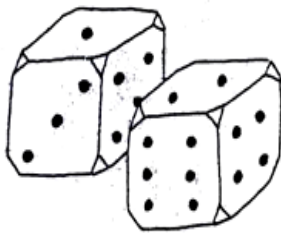

26a



56b



57b





43d

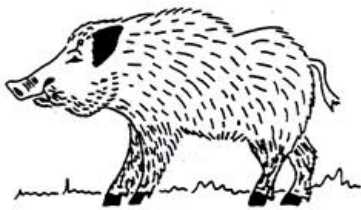

68e



69e



27a



27c

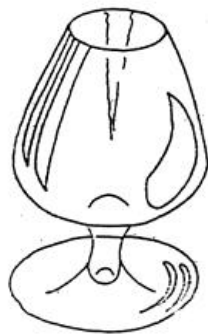

58b

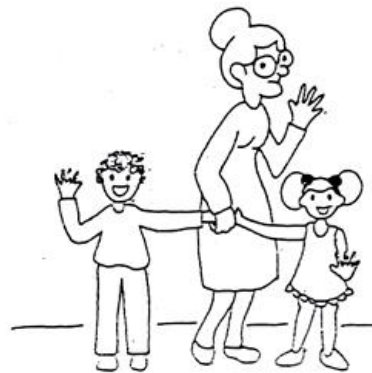



28a



59b



28c



70e

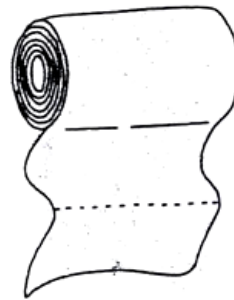

44d

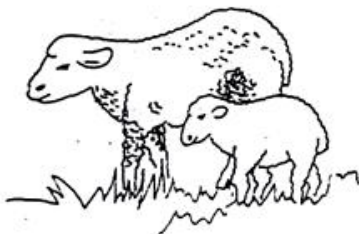

29c





30c



60b

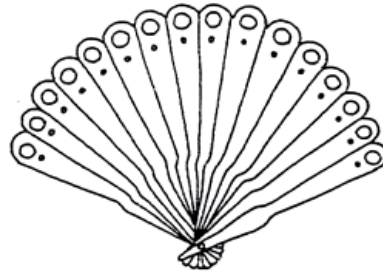

29d



71e



29a



61b







## BIBLIOGRAFÍA

- ✎ Avendaño Fernando, Miretti María Luisa, El desarrollo de la lengua oral en el aula, Estrategias para enseñar a escuchar y hablar, Edición, Homo Sapiens.